

FLIGHT MANUAL



PARTS & SERVICES

DR400
Equipped with
TAE 125-02-099
“135CDI”

S/N greater or equal to 2669 &
All aircrafts transformed by DET150102

Document n° 1002879

PAGE INTENTIONALLY LEFT BLANK

FLIGHT MANUAL

For the
DR400
**(N/S greater or equal to 2669 &
Transformed by DET150102)**
Equipped with TAE 125-02 powertrain

Type Certificate n° EASA.A367 with STC 10014219

Serial N°

Registration N°.



This manual supersedes the EASA approved flight manual for the DR400 when TAE 125-02-099 powertrain is installed in accordance with the STC (Supplemental Type Certificate) STC 10014219. This manual includes the information that the conditions of certification require to be provided to the pilot.

This aircraft must be operated within the limits of use specified in this flight manual.

**THIS DOCUMENT MUST BE KEPT PERMANENTLY
IN THE AIRCRAFT**

Document n°: 1002879

PAGE INTENTIONALLY LEFT BLANK

LIST OF REVISIONS

Edition/ Revision	Section	Description	Date	EASA Approval
Originale/0	All	Edition d'origine	04/07/2018	EASA STC 10014219 Rev.8
0/1	3	PP3-11 ; 3-12 Electrical fire procedure correction	29/11/2018	MINOR CHANGE APPROVAL EASA 10067679
	7	P7-6 Text correction P7-18 Text correction P7-26 Text correction		

The edited text is indicated by a vertical line in the margin.

- ◆ **Note:** The owner is responsible for ensuring that the aircraft manual is always up-to-date. It is therefore very important to correctly incorporate all revisions in this manual as they are received.

LISE OF SECTIONS IN FORCE

Section	Edition/revision	Date
0	0/0	07/2018
1	0/0	07/2018
2	0/0	07/2018
3	0/1	10/2018
4	0/0	07/2018
5	0/0	07/2018
6	0/0	07/2018
7	0/1	10/2018
8	0/0	07/2018

TABLE OF CONTENTS

LIST OF REVISIONS	v
LIST OF SECTIONS IN FORCE.....	vi
TABLE OF CONTENTS	vii
ABBREVIATIONS	xii
STANDARD ATMOSPHERE TABLE.....	xiv
CONVERSION FACTORS.....	xv
SECTION 0: GENERAL	0-1
CONVENTIONS	0-1
SECTION 1 : DESCRIPTION	1-1
GENERAL DIMENSIONS.....	1-1
POWERPLANT	1-4
PROPELLER.....	1-5
FUEL	1-5
OIL	1-5
SECTION 2 : LIMITATIONS.....	2-1
CERTIFICATION STANDARDS	2-1
TYPE OF USE.....	2-1
PRACTICAL CEILING	2-2
LOAD FACTOR LIMITS AT THE MAXIMUM AUTHORISED MASS ...	2-3
MAXIMUM AUTHORISED MASSES	2-3
MASS AND BALANCE	2-4
LOAD PLANNING	2-5
LOAD LIMITS	2-5
ENGINE LIMITS	2-6
ENGINE INSTRUMENT MARKINGS	2-11
EARTHING BEFORE AND DURING TANK FILLING	2-11
OPERATIONAL LIMITS IN THE "U" CATEGORY	2-12
RUNWAY SURFACE	2-12
MARKING.....	2-13
SECTION 3: EMERGENCY PROCEDURES.....	3-1
ENGINE MALFUNCTION OR LOSS OF POWER.....	3-2
At take-off, before rotation	3-2
Immediately after take-off	3-2
Engine failure in flight	3-3
LANDING WITHOUT ENGINE POWER	3-4

Restart after engine failure.....	3-5
FADEC malfunction in flight.....	3-6
ENGINE SHUT-DOWN IN FLIGHT.....	3-8
PRECAUTIONARY LANDING.....	3-9
FIRE.....	3-10
Engine fire on the ground, during start-up.....	3-10
Engine fire in flight.....	3-10
Cabin fire.....	3-11
Electrical fire.....	3-11
ENGINE MALFUNCTION.....	3-13
Oil pressure too low (<2.3 bar in cruise or <1.2 bar at idle power).....	3-13
Oil temperature is too high.....	3-14
Coolant temperature too high.....	3-15
“Coolant level” warning light illuminates.....	3-15
Gearbox temperature too high.....	3-15
Fuel temperature too low.....	3-15
Propeller rpm too high.....	3-16
Fluctuations in propeller speed.....	3-16
ICING.....	3-17
ELECTRICAL POWER MALFUNCTION.....	3-18
ELECTRICAL SYSTEM MALFUNCTION.....	3-19
INADVERTENT SPIN.....	3-19
LOSS OF ELEVATOR CONTROL.....	3-19
LOSS OF ELEVATOR TRIM CONTROL.....	3-20
LOSS OF FLAP CONTROL.....	3-20
SECTION 4 : NORMAL PROCEDURES.....	4-1
NORMAL OPERATING SPEEDS.....	4-1
Optimal climb speed.....	4-1
Maximum operating speed in turbulent air.....	4-1
Never exceed speed.....	4-1
Maximum speed with flaps.....	4-1
Landing speed (final approach).....	4-1
PRE-FLIGHT INSPECTION.....	4-2
CABIN INTERIOR CHECK PRIOR TO START-UP.....	4-7
ENGINE STARTING.....	4-8
AFTER ENGINE START.....	4-10
FADEC BACKUP BATTERY TEST:.....	4-10
WARM UP.....	4-10
TAXIING.....	4-11
BEFORE TAKE OFF.....	4-12
TAKE-OFF.....	4-15

Short take-off.....	4-15
Crosswind take-off.....	4-15
CLIMB	4-16
Normal climb (flaps up).....	4-16
Best angle of climb	4-16
CRUISE.....	4-16
DESCENT	4-17
Final approach or downwind.....	4-17
Short final	4-17
LANDING	4-18
Short field landing.....	4-18
Normal landing	4-18
Landing in crosswind or strong gusts.....	4-19
Landing distances calculation example:.....	4-20
Going around.....	4-21
AFTER LANDING.....	4-21
ENGINE SHUT-DOWN.....	4-21
After engine shut-down.....	4-21
STALLS.....	4-22
USE OF THE PARKING BRAKE	4-23
To apply the brakes	4-23
To release the brakes.....	4-23
SECTION 5 : PERFORMANCES.....	5-1
NOISE LIMITATION	5-1
CALIBRATION OF THE AIRSPEED INSTALLATION.....	5-1
STALL SPEEDS.....	5-2
WIND COMPONENT.....	5-3
TAKE-OFF PERFORMANCE	5-4
Take-off distances, 980 kg (CAT N).....	5-6
Take-off distances, 880 kg.....	5-7
CLIMB PERFORMANCE.....	5-8
Climb speeds.....	5-8
Rate of climb, flaps retracted, 980 kg	5-9
Rate of climb, flaps retracted, 880 kg	5-10
Climb time, flaps retracted, 980 kg	5-11
Climb time, flaps retracted, 880 kg	5-12
Maximum angle of climb, flaps in take-off position.....	5-13
Glide performance.....	5-13
CRUISE PERFORMANCE	5-14
At the maximum take-off mass of 980 kg (2161 lb).....	5-15
LANDING PERFORMANCE.....	5-17

SECTION 6 : MASS AND BALANCE	6-1
USE OF THE NOMOGRAM	6-3
EXAMPLE of loading calculation (dotted lines on the diagram).....	6-3
SECTION 7 : DESCRIPTION OF THE AIRCRAFT AND ITS SYSTEMS....	7-1
Airframe.....	7-1
Flap control switch.....	7-1
Elevator system.....	7-2
Aileron system.....	7-2
Rudder control.....	7-2
Control lock.....	7-2
Elevator trim.....	7-2
Roll compensation.....	7-2
Yaw compensation.....	7-3
Cabin layout.....	7-3
Panel and centre console.....	7-4
Canopy.....	7-8
Seats.....	7-8
Seat belts.....	7-9
Luggage compartment.....	7-10
Landing gear.....	7-11
Braking system.....	7-11
Parking brake.....	7-12
Use of the brakes.....	7-12
Engine.....	7-13
Propeller.....	7-14
Electrical system.....	7-14
Electrical circuit.....	7-15
Re-initialisation of FADEC.....	7-17
Fuel / Fluids.....	7-18
Engine Oil.....	7-19
Fuel system.....	7-19
Fuel level gauges.....	7-21
Tank selector.....	7-21
Heating and ventilation.....	7-23
Lighting (optional).....	7-25
Stall warning system.....	7-25
Pitot and static systems.....	7-25
Avionics and navigation.....	7-25
Headset and microphone installation.....	7-25
Flight recorder (optional equipment).....	7-26
Emergency locator transmitter.....	7-26

Hour meter	7-26
External power socket	7-27
SECTION 8 : MAINTENANCE OPERATIONS	8-1
Introduction.....	8-1
Publications for the user	8-1
Maintenance publications	8-1
Towing.....	8-1
Parking	8-1
Long-term parking	8-2
Cleaning	8-3
SECTION 9 : REGISTER OF SUPPLEMENTS.....	9-1
List of installed supplements.....	9-2

ABBREVIATIONS

sq ft	Square foot
ft	Foot
In	Inch
Nm	Nautical mile
Km	Kilometre
M	Metre
cm	Centimetre
Kt.....	Knot
m/s	Metres per second
tr/mn ou rpm	Revolutions per minute
Va.....	Manoeuvring speed
VC.....	Design cruise speed
Vfe.....	Maximum flap extended speed
Vne	Never exceed speed
Vno	Maximum cruising speed
Vso.....	Stall speed in landing configuration
Vs1	Stall speed with flaps retracted
VI.....	Indicated airspeed
Vlof	Lift-off speed
KIAS	Knot Indicated AirSpeed (Indicated airspeed in knots)
KTAS	Knot True AirSpeed (True airspeed in knots)
TAS	True AirSpeed
Km/h	Kilometre par heure
HP	Horse Power
HPa	Hectopascal
In.Hg	Inches of mercury
Mbar.....	Millibar
Zp.....	Pressure altitude
l	Litre
Imp. gal.....	Imperial gallon
Us gal.....	US gallon
Psi.....	Pound per square inch
Lb	Pound

Kg	Kilogram
°C.....	Degree Celsius
°F	Degree Fahrenheit
V.....	Volt
A.....	Amp
TAE	Thielert Aircraft Engines.
FADEC	Full Authority Digital Engine Control (Electronic engine management system)
CED.....	Compact Engine Display Multifunction instrument for displaying the parameters of the CENTURION 2-0S engine.
ISA	International Standard Atmosphere
COM.....	Communication Transceiver ELT Emergency Locator Transmitter
IFR	Instrument Flight Rules
NAV	Navigation Indicator and Receiver
AUDIO.....	Audio Control Panel
VFR	Visual Flight Rules
VHF	Very High Frequency
CPF	Firewall
LS6.....	Service Letter n°6

STANDARD ATMOSPHERE TABLE

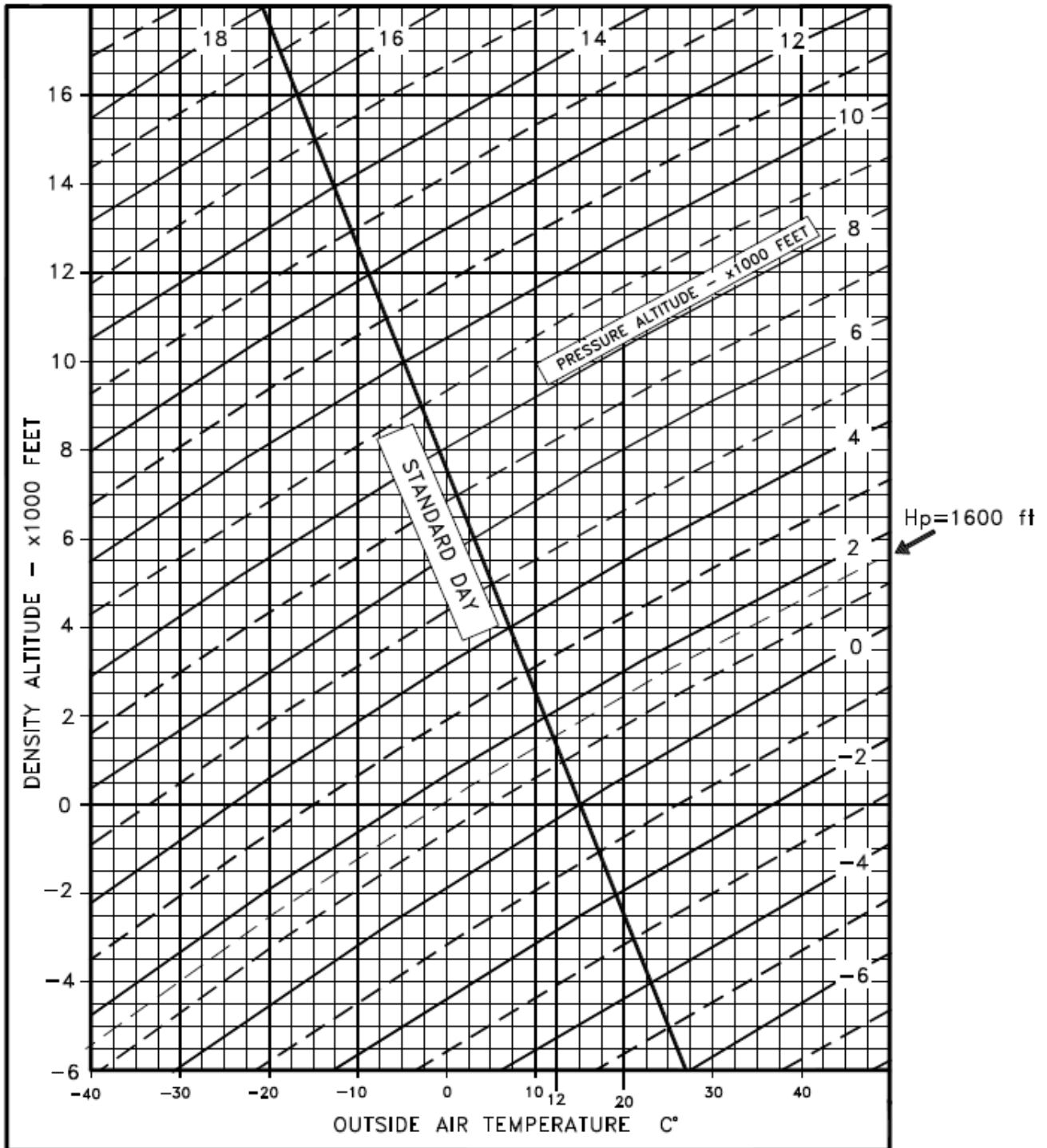

Example :

Temperature = 20°C
 Pressure altitude = 1600ft
 Standard temperature = 12°C

CONVERSION FACTORS

nautical mile	x1.852	=	kilometres
feet	x0.305	=	metres
inches	x0.0254	=	metres
inches	x25.4	=	millimetres
feet/minute	x0.00508	=	metres/second
gallons (US)	x3.785	=	litres
gallons (imp.)	x4.546	=	litres
quarts (US)	x0.946	=	litres
knots	x1.852	=	km/h
psi	x0.0689	=	bar
in. Hg	x33.86	=	mbar
lb	x0.453	=	kg
(°F – 32)	x ⁵ / ₉ -32	=	°C
kilometres	x0.539	=	nautical mile
metres	x3.281	=	feet
metres	x39.37	=	inches
millimetres	x0.03937	=	inches
metre/second	x197	=	feet/minute
litres	x0.264	=	gallons (US)
litres	x0.220	=	gallons (imp)
litres	x1.057	=	quarts (US)
km/h	x0.539	=	knots
bar	x14.51	=	psi
mbar	x0.02953	=	in. Hg
kg	x2.205	=	lb
°C	x ⁹ / ₅ + 32	=	°F

PAGE INTENTIONALLY LEFT BLANK

SECTION 0:

GENERAL

CONVENTIONS

This document uses the following conventions and warnings. They must be strictly followed in order to avoid injuries to persons, damage to equipment, decreased operational safety of the aircraft or breakdowns that may result from abnormal operation.

- ▲ **WARNING:** Failure to observe these safety rules can result in injury or even death.
- **CAUTION:** Failure to observe these particular notes and safety procedures may result in damage to the engine or to other equipment.
- ◆ **Note:** Additional information for a better understanding of an instruction.

THIS DOCUMENT IS FOR DR400 AIRCRAFT FROM AND INCLUDING SERIAL NUMBER 2669 AND IS VALID ONLY WHEN THE TAE 125-02-099 POWERTRAIN IS INSTALLED.

UPDATE AND REVISION OF THE DOCUMENT

- ▲ **WARNING:** Only an up to date flight manual allows safe operation. The current editions and revisions of this manual are available in the LS6 C.E.A.P.R
- ◆ **Note:** The edition of this manual is indicated on the first page.

PAGE INTENTIONALLY LEFT BLANK

SECTION 1 :

DESCRIPTION

GENERAL DIMENSIONS

Maximum span	(28 ft 7.3 in)	8.72 m
Total length.....	(23 ft 8.66 in)	7.20 m
Total height.....	(7 ft 3.79 in)	2.23 m
Propeller ground clearance.....	(10.2 in)	0.26 m

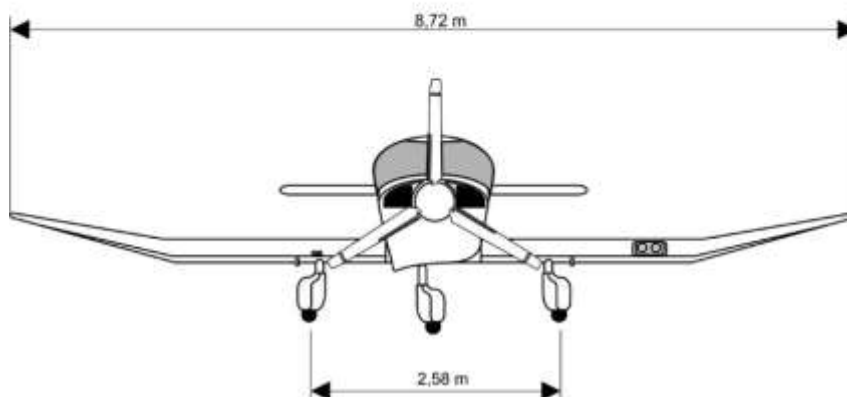
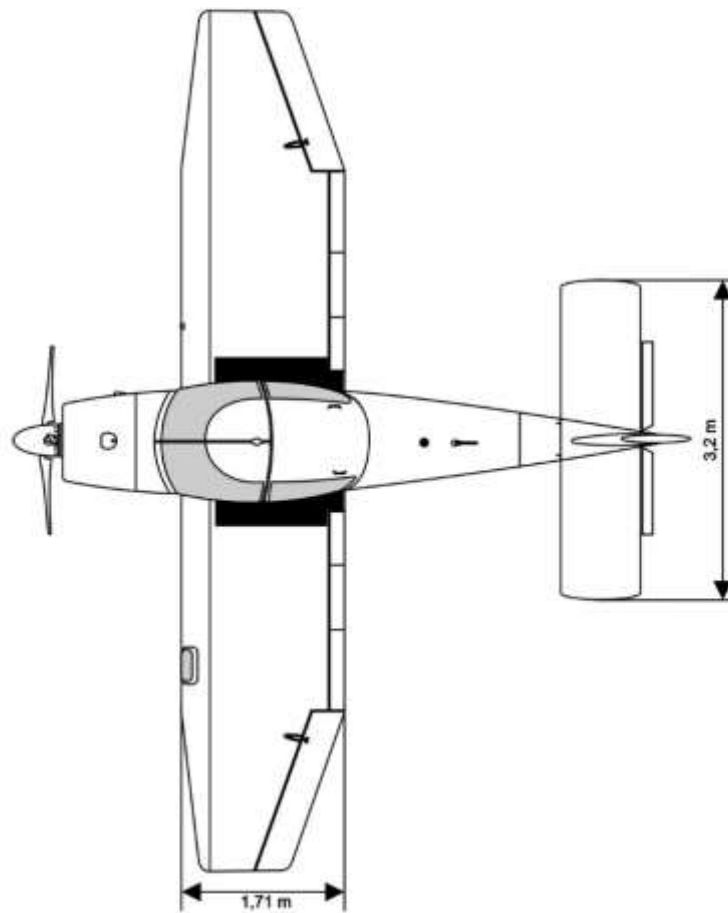
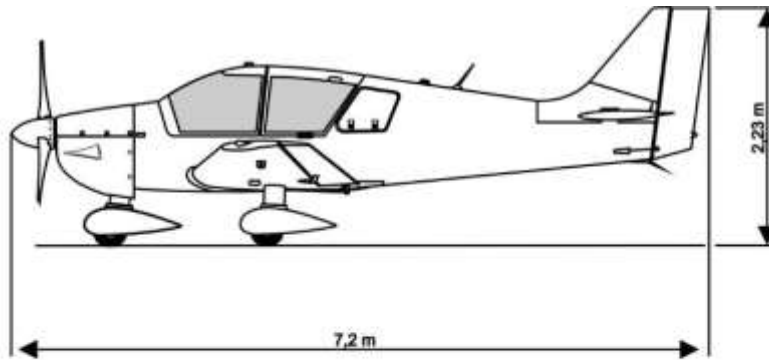

CABIN INTERIOR DIMENSIONS

Length	(5 ft 3-8 in)	1-62 m
Width (at shoulders)	(3 ft 11-2 in)	1-20 m
Width (at armrests)	(3 ft 7-3 in)	1-10 m
Height	(4 ft 0-4 in)	1-23 m

4 places, accessible from both sides via the sliding canopy.

WING

Surface area	(146-40 sq. ft.)	13-6 m ²
Profile	NACA 43013.5 amended	
Aspect ratio		5-35
Dihedral at the wingtips		14°

AILERONS

Surface area (per aileron)	(6-13 sq ft)	0-57 m ²
Span (per aileron)	(5 ft 3-8 in)	1-62 m

The ailerons are statically balanced.

FLAPS

Surface area (per flap)	(3-55 sq ft)	0-33 m ²
Span (per flap)	(6 ft 7-72 in)	2-025 m

HORIZONTAL TAILPLANE

Surface area (stabilator)	(31 sq ft)	2-88 m ²
Total surface area including trim tab	(2-8 sq ft)	0-26 m ²
Span	(10 ft 6 in)	3-20 m

VERTICAL TAILPLANE

Total surface area	(17-55 sq ft)	1-63 m ²
Surface area of the fin	(10-76 sq ft)	1 m ²
Surface area of the rudder	(6-78 sq ft)	0-63 m ²

Landing gear

Fixed tricycle

Track (8 ft 5.6 in) 2.58 m
Wheelbase (5 ft 5 in) 1.65 m
Tyre size 380 x 150 or 500 - 5
Shock absorber oil: MIL. H. 5606 - A
NORME AIR 3520

Nose landing gear

Tyre pressure (26 psi) 1.8 bar
Shock absorber pressure (72 psi) 5 bar

Main landing gear

Tyre pressure (29 psi) 2 bar
Shock absorber pressure (87 psi) 6 bar

BRAKES

The disc brakes are operated by independent hydraulic circuits on each main landing gear wheel.

Hydraulic circuit oil MIL.H.5606 - A
Norme AIR 3520

POWERPLANT

Number of engines 1
Number of cylinders 4
Engine manufacturer: Technify Motors GmbH (TAE)
Engine model: TAE 125-02-099
Configuration Cylinders in-line, double overhead camshafts
Power 135 HP at 2300 rpm

PROPELLER

- ◆ **Note :** All performances in this manual are given with the MTV-6-A-187/129 propeller. For other approved propellers, report to the documentation associated with the propeller.

Manufacturer : MT Propeller Entwicklung GmbH

Model	MTV-6-A-187/129
Diameter	1.87 m
Number of blades	3
Type	Constant Speed

FUEL

Total capacity 110 litres / 29 US gal / 24.2 Imp gal

Total usable fuel volume 109 litres / 28.7 US gal / 24 Imp gal

Unusable fuel volume 1 litre / 0.26 US gal / 0.22 Imp gal

Approved fuel types are described in SECTION 2 of this manual.

The total capacity of the tanks may be extended to 160 l (42.24 US gal / 35.2 Imp gal) (159 l usable (42 US gal / 35 Imp gal)) by the installation of the optional supplementary 50 l (13.2 US gal / 11 Imp gal) tank.

Main tank :

Total capacity 110 litres / 29 US gal / 24.2 Imp gal

Optional tank:

Total capacity 50 litres / 13.2 US gal / 11 Imp gal

OIL

The quantity of engine oil between the minimum and the maximum marks on the dipstick is 1 litre.

Total engine capacity:

Including the filters and the oil cooler: 6.7 litres

Approved types: See Section 2 - Limitations

- **CAUTION:** Only use an approved oil of the exact denomination!

The approved grades of oil are described in SECTION 2 of this manual.

PAGE INTENTIONALLY LEFT BLANK

SECTION 2 :

LIMITATIONS

CERTIFICATION STANDARDS

The DR 400/140 B aircraft has been certified under 09.11.75 in the "NORMAL" and "UTILITY" categories conforming to the following technical conditions.

- General Conditions of regulation AIR 2052 updated 6 June 1966.
- Additional Conditions for conformity with FAR Part 23 Amendment 7.
- Special conditions for the canopy release.

The installation of the Technify engine is certified in the "NORMAL" and "UTILITY" categories conforming to the following technical conditions: JAR 23 Amendment 1 Initial Issue.

TYPE OF USE

The aircraft is approved for the following usage:

- VFR by day in non-icing conditions;
- VFR by night in non-icing conditions with optional supplementary equipment. (See Section 9)
- IFR by day and night in non-icing conditions with optional supplementary equipment. (See Section 9)

NOTE

All speeds are indicated speeds unless otherwise indicated.

AUTHORISED USE

LIMITING SPEED	km/h	KIAS
Vne, never exceed	270	146
Vno, maximum in normal use	260	140
Va, maximum manoeuvring	215	116
Vfe, maximum with flaps extended	170	92

Table 2-1 - Limiting speeds

AIRSPEED INDICATOR MARKINGS		km/h	KIAS
Red line (never exceed)	Vne	270	146
Yellow arc (Operate with caution and only in calm air)	Vno-Vne	260-270	140-146
Green arc (Normal operation range)	Vs ₁ -Vno	99-260	53-140
White arc (Range with flaps extended)	Vso-Vfe	87-170	47-92

Table 2-2 - Airspeed indicator markings

PRACTICAL CEILING

The DR400 with the TAE 125-02-099 engine is certified to 16,500 ft. (5,029 m).

- ▲ WARNING:** You must comply with current regulations regarding maximum flight altitudes and take into account that high altitude flight can cause problems due to lack of oxygen.

LOAD FACTOR LIMITS AT THE MAXIMUM AUTHORISED MASS

(2095 lb) 910 kg (category "U") :

Flaps retracted n entre - 2.2 et + 4.4

Flaps extended..... $n = + 2$

(2425 lb) 980 kg (category "N") :

Flaps retracted n entre - 1.9 et + 3.8

Flaps extended..... $n = + 2$

▲ **WARNING** : Voluntary flight under negative g-loads is prohibited.
Prolonged negative g-loads (a few seconds) may damage the propeller control and the engine by loss of oil pressure.

◆ Note : The load factor limitations of the engine must also be respected. See the engine « Operation & Maintenance Manual »

MAXIMUM AUTHORISED MASSES

	Cat. "U"	Cat. "N"
At take-off	(2006 lb) 910 kg	(2161 lb) 980 kg
At Landing	(2006 lb) 910 kg	(2161 lb) 980 kg

Table 2-3 - Maximum authorised masses

MASS AND BALANCE

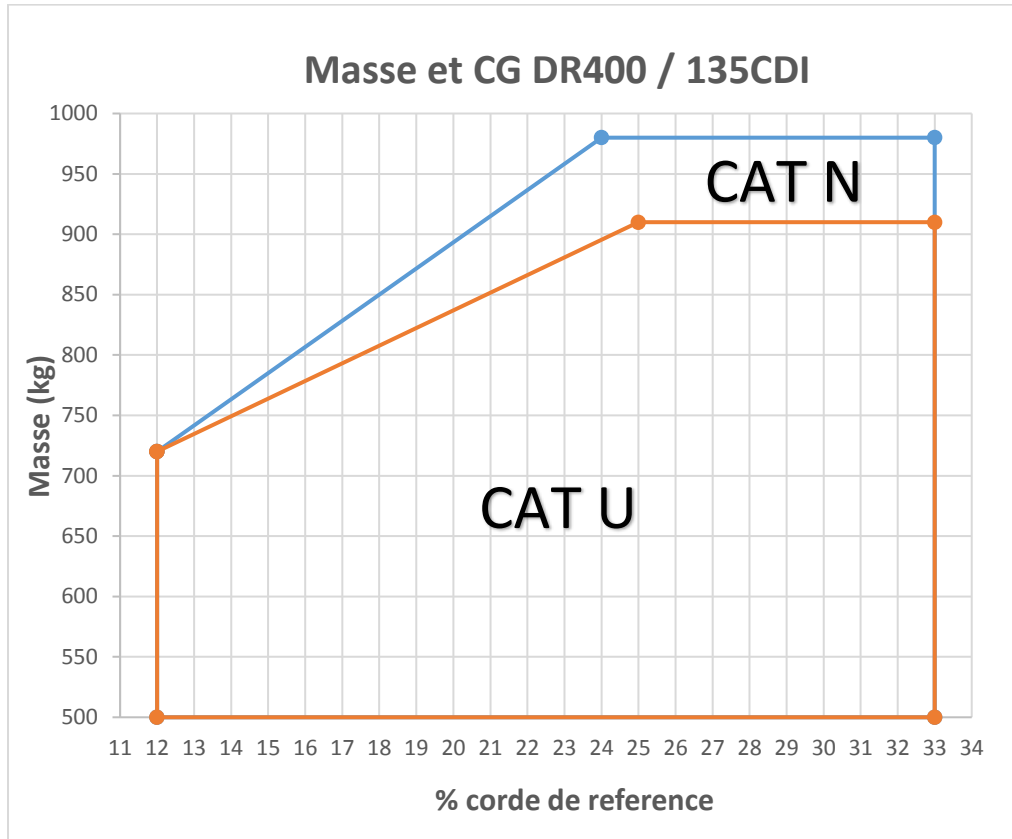

Figure 2-1 Mass and balance envelope

Normal Category

Front limit (12 % ref.): 0.205 m behind the reference plane at 720 kg

Intermediate limit (24 % ref.): 0.410 m behind the reference plane at 980 kg

Rear limit (33 % ref.): 0.564 m behind the reference plane at 980 kg

Utility Category

Front limit (12 % ref.): 0.205 m behind the reference plane at 720 kg

Intermediate limit (27 % ref.): 0.462 m behind the reference plane at 910 kg

Rear limit (33 % ref.): 0.564 m behind the reference plane at 910 kg

Levelling upper fuselage longeron

Reference plane (datum)leading edge of the rectangular part
of the wing.

Reference chord (67.3 in) 1.71 m

LOAD PLANNING

(See the nomogram, SECTION 6)

The mass of the engine oil in the sump and the mass of the unusable fuel must be included in the unladen mass of the aircraft.

	Mass kg (lb)	Lever arm m (in)
Front seats	2 x 77 (2 x 170)	0.36 – 0.46 (14 - 18)
Rear seats	2 x 77 (2 x 170)	1.19 (47)
Fuel, main tank	88 (194)	1.12 (44)
Fuel, supplementary tank (if installed)	36 (79)	1.61 (63,4)
Luggage (*)	40 (88)	1.9 (75)

Table 2-4 - Loading

* The position of the luggage has a very important influence on the balance because of the length of its lever arm. Be careful to assess the mass and balance accurately.

LOAD LIMITS

Number of occupants:

Front seats 2

Rear seats 2

Luggage compartment :

Maximum authorised mass (88 lb) 40 kg

ENGINE LIMITS

Manufacturer	Technify Motors GmbH (TAE)
Model.....	TAE 125-02-099
Maximum take-off and continuous power.....	99 kW (135 HP)
Maximum take-off and continuous rotational speed	2300 rpm
Maximum recommended cruise	85%

- ◆ **Note :** Unless otherwise specified, in this document all the values of rpm refer to the rotational speed of the propeller.

Engine operational limits for take-off and continuous operation

- ▲ **WARNING:** It is not permitted to start the engine below the temperature limits specified below.

- ◆ **Note :** The operating temperature limit is lowest temperature at which the engine can be started but not run at take-off speed. The required warming-up regime is described in section 4 of this supplement.

OIL

Oil temperature

Minimum temperature for engine starting.....	-32 °C
Minimum operating temperature	50 °C
Maximum operating temperature	140 °C

Oil pressure

Minimum oil pressure.....	1.2 bar
Minimum oil pressure (at take-off power)	2.3 bar
Minimum oil pressure during flight	2.3 bar
Maximum oil pressure.....	6.0 bar
Maximum oil pressure (cold start < 20sec).....	6.5 bar
Maximum oil consumption	0.1 l/h

Types of approved oil*

▲ **WARNING:** Only use oil that conforms to the exact specification.

Engin oil:AeroShell Oil Diesel Ultra
AeroShell Oil Diesel 10W-40
 Shell Helix Ultra 5W-30
 Shell Helix Ultra 5W-40

Gearbox oil: CENTURION Gearbox Oil N1
 Shell Spirax S6 GXME 75W-80, API GL-4
 Shell Spirax S4 G 75W-90, API GL-4
 Shell Spirax S6 ATF ZM

*Refer to the latest version of Technify Motors instruction OM-02-02.

COOLANT

Coolant temperature

Minimum temperature for engine starting -32 °C
 Minimum operational temperature60 °C
 Maximum operational temperature105 °C

Approved types of coolant*

Coolant: Water/antifreeze in the ratio of 50:50

Antifreeze: BASF Glysantin Protect plus / G48
 Mobil Antifreeze Extra / G48
 Comma Xstream Green – Concentrate / G48
 Valvoline/Zerex Glysantin / G48
 BASF Glysantin Alu Protect / G30
 Valvoline/Zerex Glysantin / G30
 BASF Glysantin Protect / G05
 Valvoline/Zerex Glysantin / G05

*Refer to the latest version of Technify Motors instruction OM-02-02.

GEARBOX

Gearbox temperature

Minimum operating temperature -30 °C

Maximum operating temperature 120 °C

FUEL

Minimum temperatures for fuel in the tanks:

Carburant	Minimum acceptable temperature in the tank before take-off.	Minimum acceptable temperature in the tank during flight.
Jet A-1, JET A, Fuel n°3 JP-8, JP-8+100, TS-1	- 30 °C	- 35 °C
Diesel	Above 0 °C	- 5 °C

Table 2-5 - Temperature limits for fuel in the tank

- ▲ **WARNING :** The above applies to mixtures of diesel and Jet-A1 in the tank:
If the proportion of diesel in the tank exceeds 10%, the temperature limitations for diesel fuel alone must be respected. If there is any doubt about the composition of the fuel in the tank then it should be assumed to be diesel.

Approved fuel types

▲ **WARNING:** The use of unapproved fuels and additives can cause a dangerous engine malfunction.

Main tank *

FuelJET-A1 (ASTM 1655)

Alternative fuel..... Diesel (DIN EN 590)

Additives for diesel fuel: Liqui Moly, « Diesel Fließ Fit » n° 5130

.....JET-A (ATSM 1655)

.....JP-8 (MIL-DTL-83133)

.....JP-8+100 (MIL-DTL-83133E)

..... Jet Fuel n°3 (GB 6537-2006)

..... TS-1 (GOST 10227-86)

..... TS-1 (GSTU 320.00149943.011-99)

Optional tank (50 litres) :

FuelJET-A1 (ASTM 1655) **ONLY**

*Refer to the latest version of the Technify Motors instruction OM-02-02.

ENGINE INSTRUMENT MARKINGS

The engine parameters of the TAE 125 system that must be monitored appear on the CED-125 (Compact Engine Display: the multifunction instrument for the display of engine parameters)

The operational ranges of the various engine parameter are shown in the following table:

Instrument	Red zone	Yellow zone	Green zone	Yellow zone	Red zone
Tachometer (rpm)			0 - 2300		> 2300
Oil pressure (bar)	0 – 1.2	1.2 – 2.3	2.3 – 5.2	5.2 – 6.0	> 6.0
Coolant temperature (°C)	< -32	-32... +60	60 - 101	101 - 105	> 105
Oil temperature (°C)	< -32	-32... +50	50 - 125	125 - 140	> 140
Gearbox temperature (°C)			< 115	115 - 120	> 120
Power (%)			0 - 100		

Table 2-6 - Engine instrument markings

- ◆ **Note :** If an engine parameter enters the yellow or red range, the CED warning light illuminates. The light can be extinguished by pressing the « CED-Test/Ack » ('Ack' = 'acknowledge') button. Pressing the button for more than one second triggers an automatic test of the instrument.

EARTHING BEFORE AND DURING TANK FILLING

Ground the exhaust system to eliminate electrostatic charges.

OPERATIONAL LIMITS IN THE "U" CATEGORY

Within the limits of this category, the following manoeuvres are permitted:

- Steep turns (60°)
- Lazy eights
- Chandelles
- Stalls (maximum pitch 20°, wings horizontal, balanced flight)

These manoeuvres must be carried out under the following conditions:

- Rear seats unoccupied
- Entry and exit speeds must be within the normal range
- Maximum recommended entry speed: 116 kt (215 km/h)

▲ WARNING: Intentional spins are prohibited!

▲ WARNING: Intentional negative g manoeuvres are prohibited!

RUNWAY SURFACE

This aircraft can take-off and land on any runway surface.

■ CAUTION: unprepared or rough runways may have holes, bumps or stones that could damage the propeller, the fairings or other projecting parts.

MARKING

The diagrams below represent the markings that must be displayed. These markings can be placards or directly printed on the desk. The shape, size, typeface and colours may vary.



Figure 2-2 - Near the cap of the main tank: 110 litres JET/DIESEL



Figure 2-3 - Near the cap of the supplementary tank, if installed

OIL DR 400/CDI
Shell Helix Ultra 5W-30
Shell Helix Ultra 5W-40
AeroShell Oil Diesel 10W-40
AeroShell Oil Diesel ULTRA



Figure 2-4 - On the inside of the oil-filler access hatch



Figure 2-5 - Near the distress beacon



Figure 2-6 - On the access hatch of the ground power socket (if installed) on the starboard side of the aircraft.

◆ Note : The socket is non-reversible to prevent polarity inversion.



Figure 2.7 - On the stabilator trim tabs

On the flaps

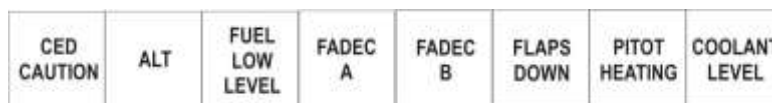

Figure 2-8 - Annunciator panel



Figure 2-9 - Near the cabin heating controls

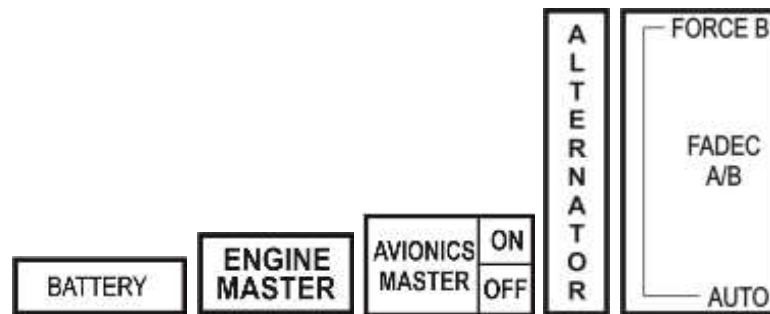

Figure 2-10 - Next to the respective switches

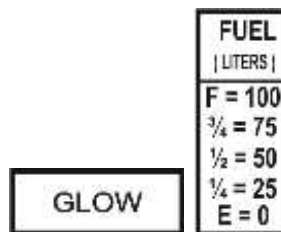

Figure 2.11 - Next to the respective indicator or gauge



Figure 2-12 - Next to the CED



Figure 2-13 - Next to the respective buttons



Figure 2-14 - Near the alternate air plunger

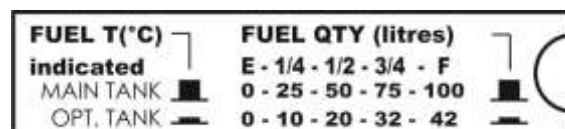

Figure 2-15 - Near the gauge of the optional fuel tank, if installed.

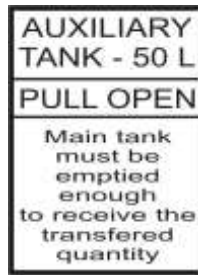

Figure 2-16 - Near the transfer plunger of the supplementary fuel tank if installed.



Figure 2-17 - On the central console, near the appropriate switches

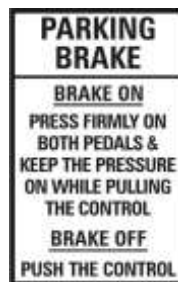

Figure 2-18 - Near the parking brake knob

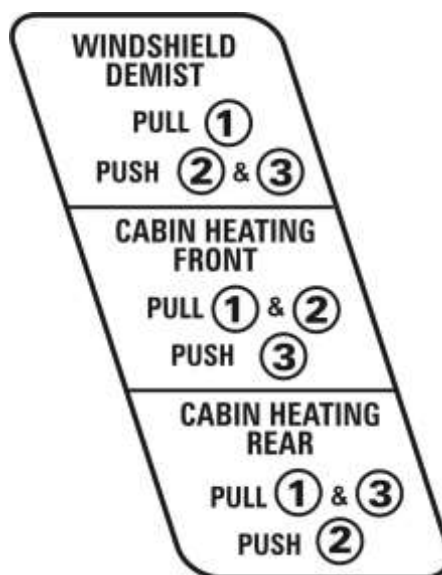

Figure 2-19 - On the right side of the cabin.



Figure 2-20 - On the heater controls



Figure 2-21 - On the ceiling of the sliding canopy



Figure 2-22 - Near the canopy locking handle



Figure 2-23 - On the arm-rests, near the canopy emergency release

DR400/140B TRAIN PRINCIPAL / MAIN GEAR		DR400/140B TRAIN AVANT / NOSE GEAR	
PNEU / TYRE	2 bar / 29 psi	PNEU / TYRE	1,8 bar / 26 psi
AMORTISSEUR SHOCK ABSORB.	6 bar / 87 psi	AMORTISSEUR SHOCK ABSORB.	5 bar / 73 psi

Figure 2-24 - On the fairings of the main wheels and of the nose wheel

BAGGAGE BAY MAX. LOAD
40 kg
SEE LOADING DIAGRAM

Figure 2-25 - In the luggage compartment or on the door of the compartment

**IL EST RECOMMANDE DE VERROUILLER A CLEF LES LOQUETS
DE PORTE DE COFFRE A BAGAGES AVANT LES VOLS
LOCKING THE LUGGAGE DOOR LATCHES WITH KEY
IS RECOMMENDED BEFORE FLIGHT**

Figure 2-26 - On the inside of the luggage compartment door

SECTION 3:

EMERGENCY PROCEDURES

CHECKLISTS

ENGINE FAILURE OR LOSS OF POWER.....	3-2
At take-off	3-2
Immediately after take-off	3-2
During flight	3-3
FORCED LANDING AFTER ENGINE FAILURE	3-5
Restart after engine failure	3-6
FADEC malfunction during flight.....	3-7
ENGINE STOPPAGE IN FLIGHT	3-9
VOLUNTARY INTERRUPTION OF FLIGHT	3-10
FIRE	3-11
Fire on the ground at start-up	3-11
Engine fire in flight	3-11
Electrical fire	3-12
ENGINE MALFUNCTION	
Oil pressure too low (<2-3 bar in cruise or < 1-2 bar at idle)	3-14
Oil temperature too high	3-15
Coolant temperature too high	3-16
"Coolant level" light illuminated.....	3-16
Gearbox temperature too high	3-16
Fuel temperature too low	3-16
Propeller rotational speed too high	3-17
Fluctuation in rotational speed of propeller	3-17
ICING	3-18
ALTERNATOR MALFUNCTION.....	3-18
When the "ALT" warning light is illuminated or when the ammeter (if fitted) indicates a battery discharge for more than 5 min, engine functioning normally	3-19
INVOLUNTARY SPIN.....	3-20
ELEVATOR CONTROL MALFUNCTION	3-20
TRIM CONTROL MALFUNCTION.....	3-20
FLAP CONTROL MALFUNCTION	3-21

ENGINE MALFUNCTION OR LOSS OR POWER

At take-off, before rotation

1. Throttle..... reduce
2. Brake and avoid obstacles
3. Engine master..... Off
4. Battery master switch and alternator switch Off
5. Fuel valve..... Closed
6. Emergency evacuation..... if necessary

Immediately after take-off

1. Establish glide
Retract flaps..... 78 KIAS (145 km/h)
Flaps in take-off position (1st stage)..... 75 KIAS (139 km/h)
2. Land straight ahead with only minor heading corrections to avoid obstacles.
3. In case of total engine failure:
FADEC A/B switch Force B
4. Battery master switch and alternator switch check ON

When landing is inevitable:

5. Engine master switch OFF
6. Flaps landing or take-off position
7. Battery master switch and alternator switch OFF
8. Fuel valve..... CLOSED
9. On very short final UNLOCK THE CANOPY
10. Land at the minimum speed
11. When the aircraft has stoppedevacuate immediately

▲ WARNING: Never turn back to the runway because the altitude after take-off is rarely sufficient.

Engine failure in flight

1. Establish glide speed :

Flaps retracted 78 KIAS (145 km/h).
(In these conditions, without wind, the aircraft's glide range is approximately nine times its height above the ground). Locate a suitable landing area.

- ◆ Note : Under these conditions the descent rate will be 850 to 900 ft/min.

- ▲ **WARNING:** A windmilling propeller will increase the rate of descent and thus severely reduce the glide range.

If altitude is sufficient to attempt a restart:

2. Electric pump ON
3. FADEC A/B switch Force B
If the engine fails to operate, return to AUTO
4. If the engine does not restart..... Reset the engine master switch (OFF then ON)
5. Battery master switch and alternator switch Check ON
6. Annunciator panel and fuel levels review
7. FADEC A, B switch Check ON
8. If the main tank is empty but with fuel available in the optional tank (if installed)open the transfer valve

If the propeller does not turn:

9. Starter ON

In principle, the propeller will continue to turn so long as the airspeed is greater than 120 km/h (65 KIAS). If the propeller stops, the reason for the stoppage must be found before attempting a restart. If the engine or the propeller is seized, do not operate the starter.

If the engine does not function normally, prepare for a "*landing without engine power*".

- ◆ Note : The two FADEC lights will flash when the fuel tank is completely empty.

- ▲ **WARNING :** The high pressure pump must be checked before the next flight.

LANDING WITHOUT ENGINE POWER

Choose an appropriate landing area:

1. Speed..... 78 KIAS (145 km/h) flaps retracted
..... 75 KIAS (139 km/h) flaps in take-off position
2. Seat belts and harnessessecure
3. Transmit a MAYDAY (121.5) and give your position and intentions.
4. Transponder.....SQUAWK 7700
5. Emergency locator beaconACTIVATE

Before landing:

6. Electric pump..... off
7. Fuel valve close
8. Engine master switch off
9. Flaps when the landing site
can easily be reached..... take-off or landing position
10. "Battery" master and "alternator" switch off
11. Canopy unlocked
12. Land at the lowest speed possible
13. Brake.....as appropriate
14. When the aircraft has stopped evacuate immediately

▲ WARNING: If the canopy is jammed then use the emergency release:
Canopy handle in « open » position.
Release the two levers on the armrests, either side of the panel, and pull them upright.

Restart after engine failure

- ◆ Note : If altitude permits and an engine restart is possible.
- 1. Speed..... flaps retracted 78 KIAS (145 km/h)
.....[max. 100 KIAS (185 km/h), min 70 KIAS (130 km/h)]
- 2. Reliable restart altitudeless than 13,000 ft.
- 3. "Battery" master and "alternator" switch Check ON
- 4. Fuel valve.....OPEN
- 5. Electric pump ON
- 6. Throttle..... CLOSED
- 7. Engine master switch OFF, then ON

The starter can be used if the propeller is not turning.

- ◆ Note : If the propeller is stationary, briefly activate the starter.
Do not use the starter if it is apparent that the engine or the propeller is seized (speed having been maintained above 70 KIAS – 130 km/h throughout).

- 8. Engine parameters check
- 9. Throttle, after restarting and running smoothly at idle adjust
- 10. Engine operationcheck available power
and the parameters

- ◆ Note : If the engine still does not start, prepare for an emergency landing; see the list « *emergency landing, engine failed* »

FADEC malfunction in flight

- ◆ Note : The FADEC consists of two independent units: FADEC A and FADEC B. If there is a malfunction of the active FADEC, the system automatically switches to the other unit.

a) One FADEC light is flashing

1. Press the FADEC “Test” button for at least 2 seconds
2. FADEC lamp extinguished (LOW category warning):
 - Continue the flight normally
 - Inform the service centre after landing.
3. FADEC lamp illuminated steadily (HIGH category warning):
 - Observe the other FADEC lamp
 - Land at the next available airfield
 - Reduce speed< 100 KIAS (185 km/h)
 - Inform the service centre after landing.

b) Both FADEC lamps are flashing

- ◆ Note : The CED power indication should be considered unreliable if both FADEC lights are illuminated. Rely on other indicators to assess engine function.

1. Press the FADEC “Test” button for at least 2 seconds
2. FADEC lamps extinguished (LOW category warning):
 - Continue the flight normally
 - Inform the service centre after landing.
3. FADEC lamps illuminated steadily (HIGH category warning):
 - Check the available engine power.
 - Expect an engine failure.
 - The flight can be continued, however, the pilot should:
 - Reduce airspeed to less than 100 KIAS (185 km/h)
 - Land as soon as possible at the nearest available airfield
 - Be prepared for an emergency landing
4. Inform the service centre after landing.

c) Abnormal engine behaviour

◆ Note : Normally, in the case of malfunction, the FADEC system automatically switches between A and B so as to select the 'healthiest' component.
If automatic switching does not occur, it is possible to manually switch over to FADEC B and check for improved engine behaviour.

1. Maximum airspeed 100 KIAS (185 km/h)
2. "FADEC A/B" switch FORCE B.
3. If there is no improvement
in engine behaviourreturn to 'Auto'

◆ Note : Switching from one FADEC to the other is usually accompanied by a short fluctuation in RPM.

ENGINE SHUT-DOWN IN FLIGHT

◆ **Note :** If it is necessary to shut down the engine in flight (for example, because abnormal engine behaviour does not allow continued flight, or there is a fuel leak, or a fire, etc):

1. Reduce speed less than 100 KIAS (185 km/h)
2. Engine master switch OFF
3. Fuel valve.....CLOSED
4. Electric pump OFF (if on)
5. If the propeller also has to be stopped, for example because of excessive vibrations) :
reduce speed to 60 - 65 KIAS (110 - 120 km/h),
flaps in take-off position.
6. When the propeller is stopped, maintain the glide at 70 - 75 KIAS (130 - 139 km/h)
flaps in take-off position.

Prepare for an emergency landing: see the list « *Emergency landing, engine failed*».

PRECAUTIONARY LANDING

1. Survey the chosen landing area, making several low-speed passes if necessary 70 KIAS (130 km/h) flaps in take-off position (1st stage).
2. Then make a precautionary approach at 65 KIAS (120 km/h), flaps in landing position (2nd stage).
3. On final, unlock the canopy.

After touch-down

Engine master switch OFF
Fuel valve CLOSED
Battery master switch OFF

- ▲ **WARNING:** If the canopy is jammed then use the emergency release:
Canopy handle in « open » position.
Release the two levers on the armrests, either side of the panel, and pull them upright.

FIRE

Engine fire on the ground, during start-up

1. Engine master switch OFF
2. Fuel valve.....CLOSED
3. Electric pump OFF
4. Battery master switch and alternator switch OFF
5. Emergency evacuation.....as required

Extinguish the flames with an extinguisher, fire blanket or sand.

▲ WARNING: Have an authorised person or workshop inspect the damage caused by the fire and repair or replace any damaged equipment before the next flight.

Engine fire in flight

1. Throttle reduce
2. Reduce speedbelow 100 KIAS (185 km/h)
3. Engine master switchOFF
4. Fuel valve CLOSED
5. Electric pump..... OFF (if it is on)
6. Battery master switch and alternator switch.....OFF
7. Cabin heat and ventilation CLOSED
8. Glide speed 78 KIAS (145 km/h)
9. Adjust the cabin ventilation for the lowest smoke in the cabin
10. Fire extinguisher (if available and if the fire has spread to the cabin)
..... use as required

Do not try to restart the engine.

◆ Note : Continue by following the procedures described in the chapter « landing without engine power ».

Cabin fire

Extinguish the fire using whatever means are available (extinguisher optional).

To eliminate the fumes, fully open the air vents.

Electrical fire

◆ **Note :** In the case of an electrical fire (combustion of insulation produces a characteristic odour):

1. Electrical equipment and radio (after a quick call) OFF
Leave alternator, battery master and engine master ON
2. Cabin ventilation..... OFF
3. Cabin heat..... OFF
4. Fire extinguisher (if available)..... use as needed

▲ **WARNING :** After the fire extinguisher has been used, make sure that the fire is extinguished before exterior air is used to remove smoke from the cabin.

5. If the fire is not extinguished, switch the battery master and alternator switches OFF.

▲ **WARNING :** If both the battery master and alternator switches are turned OFF, the engine will continue to run for a limited time using the FADEC backup battery.

- Perform an emergency landing. See « *Emergency landing, engine failed* ».
- **Do not activate the FORCE B switch; this will shut down the engine!**

▲ **WARNING:** If the battery master is switched off then the electric flaps will not operate.

If the fire has been extinguished: Land at the nearest available airfield.

6. Cabin ventilation..... ON
7. Check the circuit breakers **do not reset if open**
8. Avionics master switch ON

9. Only operate equipment essential for the continuation of the flight.

Reset the circuit breakers that have not tripped and whose function is necessary for the continuation of the flight, one at a time, waiting a little between each to check that there are no problems.

▲ WARNING: Breakers that have disconnected must not be reset. If the system has tripped then the problem is overload or short-circuit. Reconnecting the circuit may result in resumption of the fire.

ENGINE MALFUNCTION

Oil pressure too low (<2.3 bar in cruise or <1.2 bar at idle power)

1. Reduce power as quickly as possible

- ◆ Note : After a loss of oil pressure, maximum power should only be used when flying close to the ground and only for the duration necessary to regain altitude in order to make a safe landing or to determine the cause of the pressure loss.

2. Check the oil temperature: if the oil temperature is high or is close to the operating limit:

- i. Land as soon as possible at the next airfield;
- ii. Be ready for an emergency landing;
- iii. Expect an engine failure.

- ◆ Note : When operating in hot weather or climbing at low speed, the engine temperature may reach the amber range and cause the CED warning light to illuminate. The pilot can avoid further overheating as follows:

3. Increase airspeed by reducing the angle of climb;

4. Reduce power if the temperature approaches the red zone.

Oil temperature is too high

1. Increase speed (nose down) and reduce power as soon as possible.

◆ Note : If the oil temperature is too high, full power should only be used when flying close to the ground and only for the duration necessary to regain altitude in order to make a safe landing or to determine the cause of the excessive temperature.

2. Check the oil pressure. If the pressure is lower than (<2.3 bar in cruise or <1.2 bar at idle) :

- i. Land at the next available airfield;
- ii. Be prepared for an emergency landing;
- iii. Expect an engine failure.

3. If the oil pressure is in the normal range:

- i. Land at the next available airfield

◆ Note : When operating in hot weather or climbing at low speed, the engine temperature may rise. Avoid overheating the engine as follows:

1. Increase airspeed by reducing the angle of climb;
2. Reduce power if the temperature approaches the red zone.

Coolant temperature too high

1. Check the coolant level warning light
2. Increase airspeed (nose down) and reduce power
3. Check cabin heat is..... OFF

If the coolant level warning light is on, or a malfunction is suspected (because airspeed was maintained above V_y , ambient temperature is low, cabin heat is off,...) or if the coolant temperature does not decrease:

- i. Land at the next available airfield;
- ii. Be ready for an emergency landing;
- iii. Expect an engine failure.

“Coolant level” warning light illuminates

1. Increase airspeed (nose down) and reduce power
2. Cabin heat OFF
3. Monitor the coolant temperature
4. If the coolant temperature rises into the yellow zone and towards the red zone:
 - i. Land at the next available airfield;
 - ii. Be ready for an emergency landing;
 - iii. Expect an engine failure.

Gearbox temperature too high

1. Reduce power..... between 55% and 75%
2. Land at the next available airfield

Fuel temperature too low

1. Change to an altitude where the ambient temperature is higher
2. If the temperature remains too low:
 - i. Land at the nearest available airfield.

ICING

- ▲ **WARNING :** Flight into known icing conditions is prohibited. Icing has a strong negative effect on aircraft aerodynamics. Stall speed increases.

Proceed as follows when unexpectedly encountering icing:

1. Pitot heat..... ON (if installed)
If Pitot heat is not installed, expect airspeed indications to be unreliable.
2. Immediately leave the region where icing has occurred. If possible, change altitude (usually descend) to obtain an ambient temperature that is less conducive to icing.
3. Cabin heating / windshield defrosting.....as required
4. Alternate air intakeOPEN
5. Increase power. Make rapid changes of power intermittently to reduce accumulation of ice on the propeller blades.

Plan to land at the nearest suitable airfield. Make an off-airfield, precautionary landing if ice accumulation is very fast.

- ◆ **Note :** A layer of 0.5 cm (0.2 in) of ice on the leading edge of the wing significantly increases the stall speed. If necessary, approach at a higher speed than normal: 78 KIAS (145 km/h). Do not use the flaps.

ELECTRICAL POWER MALFUNCTION

▲ **WARNING :** When both the main battery and the alternator have failed, the engine will continue to run for a while using the FADEC backup battery.
Any equipment without backup power will cease to function.

- land immediately at the nearest airfield.
- do not activate the « FORCE B » switch, or the engine will stop!

◆ **Note :** The TAE 125-02-099 needs electrical power to operate. If the alternator fails, the only source of power is the battery. How long the engine can run on battery power depends on the total electrical load on the battery. The pilot must switch off all non-essential equipment and power only that equipment that is essential for continuation of the flight, depending on the situation.

Alternator failure is indicated by:

- Illumination of the «ALT» warning light;
- The voltmeter indicates to high or too low (red zone);
- The ammeter (if installed) indicates a battery discharge for more than 5 min.

During normal engine operation, when the “ALT” warning light is illuminated or the ammeter indicates a battery discharge for more than 5 minutes:

1. Alternator switch.....check ON

■ **CAUTION:** If the FADEC was supplied only by the battery, the RPM can momentarily drop when the alternator is reconnected. In any case, leave the alternator switch ON!

2. Check the « ALT » light and the voltmeter reading
3. If the problem persists:
Alternator switch..... OFF
4. Switch off all electrical equipment that is not essential for continuation of the flight;
5. Land as soon as possible at the nearest airfield.

ELECTRICAL SYSTEM MALFUNCTION

1. Check the relevant switch and circuit breaker;
2. If the system is necessary for the continuation of the flight, reset the breaker once only. If the breaker trips again, do not reset it because the equipment is faulty.

▲ WARNING: **Do not reset a system more than once.** A circuit breaker or switch is a security system. If the system has tripped then the problem is overload or short-circuit. Attempted reinstatement of the system may cause a fire.

INADVERTENT SPIN

If a spin occurs, use the following procedure:

1. Throttle reduce (pull back)
2. Rudder **AGAINST** the direction of rotation
3. Elevator..... neutral
4. Ailerons..... neutral
5. When rotation has stopped, centralise the rudder and recover within flight limitations.

◆ Note : If the flaps are down when the spin begins, retract them immediately.

LOSS OF ELEVATOR CONTROL

If elevator control is lost (accidental disconnection):

- Stabilise the aircraft in level flight, flaps retracted, at 70 KIAS (130 km/h), using the elevator trim and the throttle.
- Do not touch the trim but control the rate of descent only with the throttle. Only reduce power on short final, near the ground.

LOSS OF ELEVATOR TRIM CONTROL

If the electric trim control fails:

1. Counter using the elevator as necessary;
2. Pull the elevator trim circuit breaker;
3. Do not try to reset the circuit breaker in flight;
4. Reduce speed to minimise the effort needed to operate the elevator;
5. Find and conserve the configuration that allows the minimum effort to effect a safe landing.

LOSS OF FLAP CONTROL

FLAPLESS APPROACH:

Approach speed 70 KIAS (130 km/h)

Short final 65 KIAS (120 km/h)

When landing flapless, the landing distance will be increased by 30%.

SECTION 4 :

NORMAL PROCEDURES

LOADING

Before every flight, ensure that the total mass and centre of gravity are within the prescribed limits. For these, refer to SECTION 6.

NORMAL OPERATING SPEEDS

The speeds listed below are the indicated airspeeds recommended for normal operation of the aircraft.

They apply to a standard aircraft, at maximum take-off mass, in standard atmosphere, at sea level.

They may vary from one aircraft to another, according to the equipment installed, the condition of the aircraft and the engine, the atmospheric conditions and the skill of the pilot.

Optimal climb speed

Flaps in take-off position (1st stage)76 KIAS (140 km/h)
Flaps retracted78 KIAS (145 km/h)

Maximum operating speed in turbulent air

Flaps retracted140 KIAS (260 km/h)

Never exceed speed

Flaps retracted146 KIAS (270 km/h)

Maximum speed with flaps

Flaps in landing position (2nd stage).....92 KIAS (170 km/h)

Landing speed (final approach)

Flaps in landing position (2nd stage).....62 KIAS (115 km/h)

PRE-FLIGHT INSPECTION

To be done before each flight.

During all exterior inspections, inspect all the joints, the pivot pins and the bolts; check that the fabric is not damaged, that it is in good condition and that there are no dents or tears; check that all control surfaces are moving correctly and that there is no excessive play; check that there are no leaks near the fuel tanks or fuel lines. Identify and report anything abnormal.

In cold weather, remove all frost, ice and snow from the fuselage, the fixed surfaces and the control surfaces. Check that there is no ice or debris that could interfere with the movement of the control surfaces. Check that there is no accumulation of snow or ice in the wheel fairings.

If so equipped, check that the pitot probe heater is working by turning on the pitot heat for less than 30 seconds.

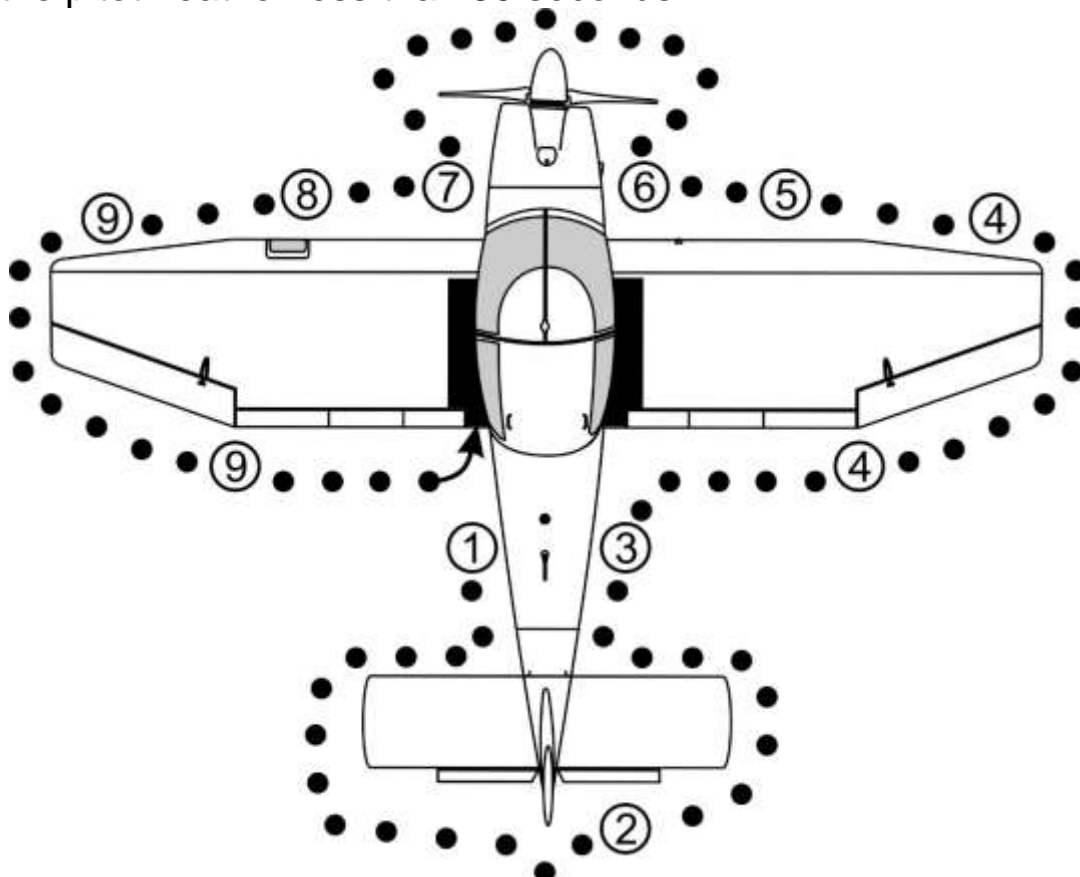

Figure 4-1 - Pre-flight inspection

Engine master switch OFF
 Avionics master switch (if fitted)..... OFF
 Flight controls free with movement in the correct direction
 Battery master switch ON

▲ WARNING : when the battery master is on, when using ground power, or when turning the propeller, treat the propeller as live.

Flapscheck operation
 Trimcheck operation
 Fuel quantity..... check
 Fuel gauge conforms to dip-stick (if so equipped)..... check
 Fuel temperature check
 Coolant level.....Lamp OFF
 Oil pressure warning light Illuminated
 Battery master switch OFF
 Aircraft documents.....on board
 Luggageproperly stowed

Check the travel of the control surfaces, then circle the aircraft, starting with the left side of the fuselage (see figure 4-1).

1

- a) Fuel cap..... in place, locked
- b) Fuel tank vents (underneath) unobstructed
- c) Static port clean, unobstructed
- d) Main tank fuel drain
 Optional supplementary tank fuel drain (if installed).....
strain and inspect the samples

▲ WARNING: Testing the fuel is essential before each flight and after each refuelling to ensure that there are no impurities nor water in the tanks.
 Because of their high pressure pump, diesel engines are particularly sensitive to the presence of water.
 To perform a reliable test the aircraft must be on a horizontal surface and have been immobile for about 30 minutes.
 The sample must be taken in a clean container intended for the purpose and which allows the identification of impurities and water.
 If, after repeated sampling, evidence of contamination still exists, the airplane should not be flown. All evidence of contamination must be removed before further flight.

▲ WARNING: Ensure that the type of fuel is correct (Diesel or JET-A1 and not AVGAS: the colour must not be blue)

2

- a) Stabilatorcondition of the surface, correct movement
- b) Rudder.....full and correct movement

3

- a) Static portsclean, unobstructed

4

- a) Flaps, ailerons check condition and joints
- b) Wing-tip and navigation lights (if fitted) check operation

5

- a) Stall warner clean, test
- ◆ Note : With the battery master switched on, test the stall warner to make sure that the warning signal is activated when the tab is lifted.
- b) Right main undercarriage check fastenings and condition
normal shock absorber position
tyre condition: inflation and wear
check fairings: condition and fastenings, no accumulation of debris

6

- a) Fuel filters drain.....strain and inspect the sample
 - b) Exhaust pipe rigid
 - c) Engine cowlings secured..... check
 - d) Propeller..... clean, in good condition
 - e) Propeller boss no play
 - f) Air intakesclean, unobstructed
 - g) Gearbox oil level..... check
- ◆ Note : The oil must cover at least half of the inspection window.

7

- a) Nose gear..... check fairing attachment and condition
shock absorber compression normal
tyre condition: inflation and wear
check for accumulation of debris inside the fairings
tow-bar removed
- b) Engine oil check level, cap secured, hatch closed
- c) Canopy cleanliness check

8

- a) Left main undercarriage..... check fairing attachment and condition
shock absorber compression normal
tyre condition: inflation and wear
check for accumulation of debris inside the fairings
- b) Pitot.....clean, unobstructed
- c) Lights (if fitted)..... clean lenses

9

- a) Wing-tip and navigation lights (if fitted) check condition
- b) Flaps, ailerons check and condition and joints

CABIN INTERIOR CHECK PRIOR TO START-UP

1. Canopy closed and locked
2. Parking brake on
3. Front seats set and locked
4. Belts and harnesses adjusted and fastened
5. Flight controls free, without play or excessive friction, move in the correct direction, (check rudder during taxiing)
6. Battery master ON
7. Auto-test of CED lights observe
8. Alternator switch ON
9. Annunciator panel Test, set DAY/NIGHT as appropriate
10. Circuit breakers ENGAGED
11. Elevator trim movement and direction verified, then returned to take-off position
12. Fuel quantity check that it is sufficient for the flight

◆ Note : Check that the fuel gauge reading concurs with the visible fuel level in the tanks and/or the documentation in the journey log.

◆ Note : The electronic engine management system requires a power supply to operate. The battery and alternator circuit breakers must be ENGAGED in normal operation. Disengaging these circuit breakers is only permitted for testing and in emergencies.

13. All electrical switches and avionics OFF

■ CAUTION: The “avionics” master switch must be off during engine start-up so as to avoid possible damage to the avionics equipment.

◆ Note : It is preferable to retract the flaps fully or to the take-off position before starting to avoid any projection.

ENGINE STARTING

1. Canopy..... Closed
2. Strobe ON
3. Fuel level and temperature..... check
4. Fuel valve..... check operation, OPEN
5. Alternate air..... closed
6. Electric pump ON
7. Throttle..... REDUCED
8. Propeller area..... clear
9. Engine master switch ON
10. FADEC lights..... check OFF
11. Glow plug indicator..... wait until EXTINGUISHED
12. Starter ENGAGE

◆ **Note:** Release the starter as soon as the engine starts, leaving the throttle in the idle position.

■ **CAUTION:** Limit the use of the starter to 10 seconds of operation, separated by 20 second intervals to allow cooling. Allow the starter to cool for 30 minutes after 6 attempts.

■ **CAUTION:** If the aircraft is not equipped with a ground power plug, starting the engine by using an external power source is prohibited.

▲ **WARNING:** If the main battery is not capable of operating the starter, perform the maintenance necessary to have an operational battery.

13. Check.....oil pressure / idle 890 rpm

■ **CAUTION :** If the oil pressure does not reach 1 bar within 3 seconds, stop the engine immediately!

- 14. « CED » warning light Acknowledge & cancel
- 15. ALT light..... Check OFF
- 16. Ammeter (if installed) Check for positive charging current
- 17. FADEC lights check OFF
- 18. Depression indicator (if installed)Check

AFTER ENGINE START

1. Electric pump OFF
2. Canopy CLOSED & LOCKED
3. Belts and harnesses.....FASTENED

FADEC BACKUP BATTERY TEST:

- a) Alternator switch..... OFF, the engine must operate normally
- b) Battery master switch OFF, for at least ten seconds; the engine must operate normally, the red FADEC lights must not illuminate.
- c) Battery master switch ON
- d) Alternator switch..... ON

▲ WARNING: Make sure that both the battery master switch and the alternator switch are on!

4. Avionics master switch & radio/nav instruments ON, set
5. ALT light..... check OFF
6. Voltmeter..... Check in green zone
7. Altimeter..... Set
8. Horizon, & directional gyro (if fitted) Set

WARM UP

1. Faster warming of the coolant can be facilitated by pulling the cabin heat control.
2. Let the engine warm up at for 2 minutes at idle (about 890 rpm).
3. Increase the speed to a maximum of 1400 rpm until the oil temperature reaches 50°C and the coolant temperature reaches 60° (CED: all the LED lights..... green).

TAXIING

1. Parking brake.....off
2. Toe brakes..... test
3. Do not exceed 1400 rpm when the yellow LEDs « oil temperature» and « coolant temperature » are illuminated on the CED.
4. During changes of direction during taxiing:
 - a. Turn indicator (if fitted) check
 - b. Direction indicator (if fitted).....check operation
 - c. Magnetic compass check

■ **CAUTION:** While taxiing, steer with the rudder pedals (nose-wheel steering). It is not necessary to brake to change direction. Taxi at a moderate pace using the minimum power necessary to move without permanent use of the brakes. Continuous or excessive braking can cause overheating or damage to the brakes and nearby systems.

BEFORE TAKE OFF

1. Parking brake ON
2. Canopy CLOSED AND LOCKED
3. Flight controls.....free and in the correct direction
4. Flight and navigation instruments..... check, set
5. Cabin heat.....as needed
(off if heating is not required)
6. Fuel valve..... OPEN
7. Fuel quantitycheck that it is sufficient for the flight
8. Elevator trim circuit breaker..... Engaged
9. Elevator electric trim controlverify trim tab moves up and down
..... check that movement is in the correct direction
10. Elevator trim take-off position

◆ **Note :** Do not use the electric elevator trim during take-off and initial climb.

11. FADEC test:

- a. Power lever FULLY BACK
(both FADEC lights must be off)
- b. FADEC 'test' button PRESS AND HOLD the button
until the test is complete
- c. The two FADEC lights ILLUMINATED,
the propeller speed increases

◆ **Note :** If the FADEC test does not start, check that the power lever is fully back. If not, move it fully back and restart the FADEC test.

▲ **WARNING :** If the FADEC lights do not illuminate at this point in the test, then the test has failed and take-off should not be attempted.

- d. The FADEC automatically switches to unit B (only the FADEC B light is illuminated).
- e. The propeller control is activated, the propeller speed decreases momentarily.
- f. The FADEC automatically switches to unit A (only the FADEC A light is illuminated).
- g. The propeller control is activated, the propeller speed decreases momentarily.
- h. The FADEC A light extinguishes, RPM returns to idle, the test is complete.
- i. FADEC test button RELEASE

▲ **WARNING:** If there are several misfires or the engine stops during the test then take-off must not be attempted.

▲ **WARNING:** The whole test procedure has to be completed without any discrepancy. If the engine stops or the FADEC lamps flash, take-off is PROHIBITED. This still applies even if the engine seems to run normally after the test.

◆ **Note :** If the FADEC test button is release before the end of the test, the FADEC immediately resumes normal operation.

◆ **Note :** When switching from one FADEC to the other, a temporary increase in engine speed is normal.

12. CED Check that all the LEDs are GREEN

13. Power lever FULLY FORWARD,
Minimum engine load displayed: 94 %,
Rotational speed: between 2240 and 2300 rpm

◆ **Note :** The power check must be performed in a location free of debris so as to minimise the risk of damage to the propeller or other parts of the aircraft.

14. Power lever IDLE

15. Engine instruments and voltmeter CHECK

-
- 16. Depression indicator (if installed)..... CHECK
 - 17. Flaps full down, then back to the take-off position
 - 18. Electric pump ON
 - 19. Radios and avionics ON, set
 - 20. Power lever friction control SET as desired
 - 21. Brakes..... RELEASE

TAKE-OFF

Short take-off

1. Flaps..... (1st stage) take-off position
2. Full throttle, brakes on,
then release the brakes..... 2300 rpm before rotation
3. Rotation speed..... 52 KIAS (96 km/h)
Initial climb speed 61 KIAS (113 km/h)
4. After obstacle clearance 78 KIAS (145 km/h)
5. Flaps..... RETRACT
6. Electric pump OFF

Crosswind take-off

1. Flaps..... (1st stage) take-off position
2. Ailerons..... into wind

◆ Note : Take off at a slightly higher speed than normal. Correct drift as normal (maximum bank angle close to the ground: 15°).

Demonstrated crosswind limit..... 22 kt (40 km/h).

CLIMB

Normal climb (flaps up)

Best rate of climb 78 KIAS (145 km/h) from 0 to 9500 ft; 75 KIAS (140 km/h) until 11,500 ft; 72 KIAS (133 km/h) above 11,500 ft.

When the best rate of climb is not required, climbing at a higher speed will improve forward visibility.

1. Power lever Fully forward

Best angle of climb

Best angle of climb is achieved at 65 KIAS (120 km/h), flaps in take-off position (1st stage).

▲ WARNING: This type of climb should only be used exceptionally for the clearance of obstacles (because engine cooling will be compromised).

CRUISE

◆ Note : Refer to Section 5 for RPM settings and cruise performance.

1. Power.....Maximum 100 % (maximum continuous power)
Recommended: 75% or less
2. Elevator trim.....ADJUST
3. Respect the limits of oil pressure, oil temperature, coolant temperature and gearbox temperature (CED LEDs and CED warning light on annunciator panel) MONITOR regularly
4. Fuel temperature and level
(gauges and low fuel level warning light) MONITOR regularly

▲ WARNING: If the fuel temperature falls below the minimum acceptable, expect an engine failure. Excess fuel returns from the injectors to the main tank, heating the fuel in the tank; a drop in fuel temperature indicates a serious problem.

5. FADEC warning lamp MONITOR regularly

- ◆ Note : If the aircraft is fitted with a supplementary fuel tank, check that there is sufficient space in the main tank to take all the fuel in the supplementary tank before transferring fuel from the supplementary tank to the main tank. If there is insufficient space in the main tank, excess fuel will be lost through the breather.

DESCENT

1. Power as required to achieve the desired rate of descent.
2. Pull the cabin heater knob to keep the coolant warm if the power setting is low. If the coolant temperature is in the amber zone and the CED caution lamp is illuminated, increase power to return the coolant temperature to the green zone.

Final approach or downwind

1. Electric pump ON
2. Cabin (seats, belts) check
3. Flaps below 92 KIAS (170 km/h),
take-off position (1st stage)
4. Speed 81 KIAS (150 km/h)
5. Elevator trim SET

Short final

1. Flaps below 81 KIAS (150 km/h)
Landing position (2nd stage)
2. Approach speed 62 KIAS (115 km/h)

- ◆ Note : Approach speed can be increased to 70 KIAS (130 km/h) to improve manoeuvrability. This may increase the landing distance.

3. Elevator trim SET

- ◆ Note : Do not use the electric elevator trim on short final and during the flare.

LANDING

Short field landing

- ◆ **Note :** The landing distances in section 5 were obtained with the procedure below.

To land on a short runway, in calm conditions, approach at 62 KIAS (115 km/h) with the flaps in the landing position.

Start to reduce engine power when passing 50 ft (15 m). Touchdown must be at idle power and on the main wheels first.

Immediately after the main wheels touchdown, apply as much braking force as possible without locking the wheels until the aircraft has stopped. Keep the stick back during braking to maintain maximum load on the main wheels (thus maximising braking efficiency).

Normal landing

In general, the normal landing procedure is used when optimum landing performance is not required.

- ▲ **WARNING:** Ensure that the runway length is at least 1.5 times the landing distance in section 5.

A normal landing is made with full flap from an approach speed between 62 KIAS (115 km/h) and 70 KIAS (130 km/h).

Surface wind and turbulence are usually the main factors in determining the most comfortable approach speed.

- ◆ **Note :** Approach speeds greater than 70 KIAS (130 km/h) will increase the landing distance so ensure that the available landing distance is at least 1.5 times the landing distance in section 5.

Touchdown must be at idle power and on the main wheels to reduce the landing speed and the necessary braking force.

Slowly lower the nose wheel onto the runway after the aircraft has slowed.

Once the nose wheel is straight, allow the front damper to compress to release the nose wheel lock and allow nose wheel steering.

Smoothly move the stick forward to the neutral position.

Apply the brakes as required.

- ◆ Note : Landing with the flaps retracted will increase the landing distance by about 30%.

Landing in crosswind or strong gusts

1. Flaps (1st stage) take-off position is recommended
2. Approach speed 70 KIAS (130 km/h) + 1/2 gust speed
3. Drift correct in the normal way

Touchdown on the main gear first.

Avoid balancing on the main gear and put the nose wheel down as soon as possible to compress its suspension, unlock the nose wheel steering mechanism, and enable nose wheel steering (see SECTION 7).

Insufficient force on the nose wheel may cause the steering mechanism to remain locked in the longitudinal axis of the aircraft, which may prevent directional control of the aircraft.

Push the stick into wind.

Demonstrated crosswind limit 22 kt (40 km/h)

- ◆ Note : Because of the increased approach speed and the possible use of only the first stage of flap, the landing distance will be increased by +50%.

- REMARQUE : For strong gusts, the speed and flap position must be such that V_{fe} is not exceeded.

Landing distances calculation example:

- Headwind : 10KT
- Air temperature : 15°C
- Altitude : 0 ft
- Paved and dry runway
- Weight: 980 kg (max.)

Landing distance with landing on short runway procedure.

Reminder: The landing distance is the distance from the 15m (50ft) to the complete stop.

Table 5-10 section 5

Landing distance without wind correction = **507m**

Correction of the Headwind influence section 5

Corrected distance = $507 * 0.85 =$ **431 m**

Landing distance with normal landing procedure.

Same as above but with 1.5 coefficient

Distance to consider = $1.5 * 431 =$ **647 m**

Landing distance in crosswind or strong gusts

- Crosswind : 20KT full crosswise

Flaps: take-off position (1st stage)

Approach speed = 70 KIAS (130 km/h)

Safety distance = $1.5 * 507 =$ **761 m**

- Gust wind : 20KT

Flaps: take-off position (1st stage)

Approach speed = 70KIAS (130 km/h) + 10KT (18.5 km/h) = 80KIAS (148.5 km/h)

Safety distance = $1.5 * 507 =$ **761m**

Going around

1. Pitch.....Take-off
2. Power lever..... Full (push)
3. Speed65 KIAS (120 km/h)
4. Retract the flaps to the take-off position (1st stage), then adjust the speed for a normal climb of 75 KIAS (140 km/h).

AFTER LANDING

1. Electric pump OFF
2. Flaps.....RETRACT
3. Navigation instruments..... OFF

ENGINE SHUT-DOWN

1. Parking brake..... ON
2. Power lever.....IDLE (1 min)
3. Flaps..... DOWN
4. COM/NAV and electrical equipment..... OFF
5. Engine master..... OFF

◆ Note : The engine must run at idle (power lever at minimum) for 1 minute before shut-down to protect the turbocharger.

After engine shut-down

1. Battery master switch..... OFF
2. After placing the wheel chocks.....release the parking brake

STALLS

The stall characteristics of the DR400 are traditional. Power-off stalls are accompanied by a slight floating of the nose if the stick is held fully back. The power-off stall speeds at maximum mass are given in section 5, Performance.

During a stall at altitude, while the indicated speed decays slowly it is possible to feel a slight vibration of the cabin and to hear the stall warner sound at 5 to 10 kt before the stall. Normally, the stall is indicated by a slight yaw and it is possible to hold the wings level or in a bank by co-ordinated use of the ailerons and rudder. When the stall warner sounds, to recover, push the stick forward to allow the aircraft to accelerate, apply full throttle if necessary and bring the wings level with co-ordinated use of the controls.

▲ WARNING: Extreme caution must be exercised to avoid uncoordinated, abrupt or extreme manoeuvres near the stall, especially near the ground.

USE OF THE PARKING BRAKE

To apply the brakes

Press both brake pedals. Maintain the pressure and pull the parking brake plunger control upward.

Release the pressure on the pedals; the parking brake control must remain in the pulled (extended) position.

Or

Pull the parking brake plunger control up.

Press both brake pedals firmly, then release the pedals. The parking brake control must remain in the pulled (extended) position.

To release the brakes

Push the parking brake plunger fully down.

- ▲ **WARNING:** Do not pull the parking brake control during flight. If landing with the parking brake engaged, the brakes will be fully applied as soon as the toe-brake pedals are pressed. This can lock the wheels and cause a tyre burst or a fire.

PAGE INTENTIONALLY LEFT BLANK

SECTION 5 :

PERFORMANCES

- ◆ Note : **All performance figures in this manual are with the MTV-6-A187/129 propeller.**

NOISE LIMITATION

In accordance with ICAO regulations, Annex 16, Volume 1, Part II, the permitted noise level for the DR400/140B at maximum take-off mass of 980 kg (2161 lb) is 78.4 dB(A).

The noise level measured under the conditions specified in the aforementioned Regulation is:

- MT Propeller MTV-6-A-187/129 - silencer "Langer LA49"	70.2 dB(A)
--	------------

CALIBRATION OF THE AIRSPEED INSTALLATION

Correction of the air speed indicator

$VC = (VI + \text{calibration})$ is practically equal to VI

The above formula does not take into account the air speed indicator's own tolerance

Altitude correction

The altitude correction is practically equal to zero. The altimeter's own tolerance is not taken into account.

- ◆ Note : **All speeds in this manual are indicated speeds unless otherwise specified.**

PARAMETERS AFFECTING THE PERFORMANCE

The calculated performance data in this section are based on data derived from flight tests, with the aircraft and engine in good condition and utilising average piloting skills. Unless otherwise indicated, the ambient conditions are those of a standard atmosphere.

◆ Note : Whenever possible, choose the most conservative values of the following data so as to have a greater safety margin and to deal with unforeseen events during flight.

A conservative value for performance can be established by taking the next highest values for mass, altitude and temperature.

STALL SPEEDS

Engine idle Mass 980 kg (2161 lb)	KIAS (km/h)		
	0°	30°	60°
Pitch			
Flaps retracted	54 (99)	58 (106)	76 (140)
Flaps 1 st stage, take-off position	50 (92)	53 (98)	70 (130)
Flaps 1 st stage, take-off position	47 (87)	51 (93)	67 (123)

Table 5-1 - Stall speeds

WIND COMPONENT

Example:

Heading =	10°	Wind direction vs heading	10°
Wind direction =	60°	Crosswind =	12Kt
Wind speed =	15 Kt	Headwind =	10Kt

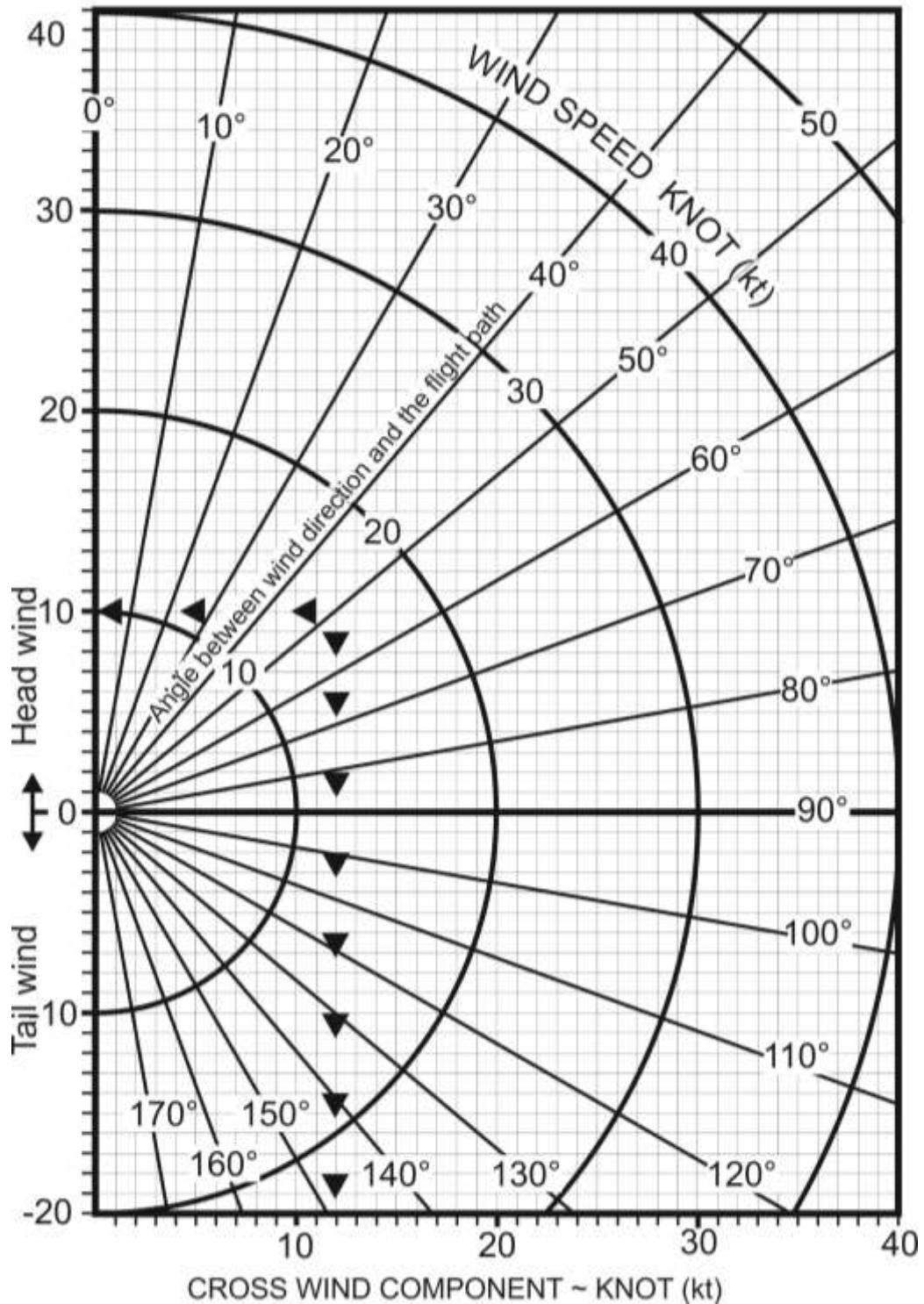

TAKE-OFF PERFORMANCE

The take-off distances show the ground roll and the distance to clear 50 feet (15 metres) above the ground. These distances are based on a short take-off technique.

Conservative values can be determined by reading the next highest values for mass, altitude and temperature.

Influence of head wind:

- for 10 KIAS, multiply by 0.85
- for 20 KIAS, multiply by 0.65
- for 30 KIAS, multiply by 0.55

Influence of tail wind:

- Add 10% to the distance for each 2 kt increase in tail wind.

◆ Note : So as to limit take-off distances, it is not recommended to attempt to take off with a tailwind in excess of 10 kts.

Grass runway:

- Add 15% for short, dry, grass.

◆ Note : If the runway is covered with snow or slush, remember that the take-off distance will be considerably increased as the thickness of the snow or slush increases. The thickness and consistency of the surface layer may be sufficient to make take-off impossible.

Sloping runway

An upward slope of 2% (2 m in 100 m) increases the take-off distance by 10%. The effect on the ground roll may be greater.

- ◆ Note : The following data gives the take-off performance of a clean, insect-free and dry, aircraft, on a horizontal runway, as a function of temperature and pressure altitude. It is possible to establish conservative distances by reading the next higher value for mass, altitude and temperature.
If the brakes are not applied during the engine run-up, the effective distance begins where full power is obtained.

Take-off distances, 980 kg (CAT N)

Conditions:

- Maximum take-off weight 980 kg.
- No wind, flaps in take-off position (1st stage), full power before releasing the brakes.
- Runway hard, dry and flat.
- Take-off speed V_{lof}57 KIAS (105 km/h)
- Speed on passing 15 m (50 ft.).....61 KIAS (113 km/h)

Pressure altitude (ft.)	Take-off Distance (m) at 980 kg (2161 lb)					
	ISA Conditions		ISA +10 °C		ISA + 20 °C	
	ground roll	to 15m height	ground roll	to 15m height	ground roll	to 15m height
0	240	440	260	480	280	520
1000	260	470	270	500	290	540
2000	270	490	290	530	310	570
3000	280	510	300	550	320	590
4000	300	540	320	580	340	630
5000	310	580	330	620	360	670
6000	330	620	350	660	380	720
7000	360	690	380	730	400	790
8000	390	760	410	810	430	880
9000	410	810	430	850	450	930

Table 5-2 - Take-off distances (m) at 980 kg (maximum take-off mass).

Take-off distances, 880 kg

Pressure altitude (ft.)	Take-off Distance (m) à 880 kg (1940 lb)					
	ISA Conditions		ISA +10 °C		ISA + 20 °C	
	ground roll	to 15m height	ground roll	to 15m height	ground roll	to 15m height
0	190	350	210	380	220	410
1000	200	370	220	390	230	430
2000	210	390	230	410	250	450
3000	220	400	240	430	260	460
4000	240	430	250	460	270	490
5000	250	450	270	480	290	520
6000	270	490	290	520	310	560
7000	290	540	310	570	330	620
8000	310	590	330	620	350	680
9000	330	630	350	660	370	720

Table 5-3 - Take-off distances (m) at 880 kg

CLIMB PERFORMANCE

At sea level

Flaps in take-off position (1 st stable)	65 KIAS (120 km/h)
Flaps retracted.....	78 KIAS (145 km/h)

Climb speeds

- 78 KIAS (145 km/h) from 0 to 9500 ft.;
- 75 KIAS (139 km/h) until 11500 ft.;
- 72 KIAS (133 km/h) above 11500 ft.

The tables of climb speed, take-off and en route, show the climb speeds for various situations. The time, fuel quantity and climb distance table can be used to determine the time, fuel consumption and climb distance from sea level to a specific pressure altitude. Once again, conservative values can be obtained by using the next lower value for altitude at the start of the climb and the next higher value for altitude at the end of the climb.

Rate of climb, flaps retracted, 980 kg

Pressure altitude (ft.)	Climb speed KIAS (km/h)	Rate of climb (ft/min) at 980 kg (2160 lb)		
		ISA	ISA + 10 °C	ISA + 20 °C
0	78 (145)	680	660	630
1000	78 (145)	680	660	630
2000	78 (145)	675	660	630
3000	78 (145)	670	660	630
4000	78 (145)	650	640	600
5000	78 (145)	620	610	570
6000	78 (145)	580	570	540
7000	78 (145)	550	540	510
8000	78 (145)	520	510	480
9000	78 (145)	490	480	450
10000	75 (139)	370	370	350
11000	75 (139)	340	340	330
12000	75 (139)	300	300	300
13000	72 (133)	260	260	260
14000	72 (133)	210	210	210
15000	72 (133)	170	170	170
16000	72 (133)	130	130	130

Table 5-4 - Rate of climb at 980 kg (maximum take-off mass)

Rate of climb, flaps retracted, 880 kg

Altitude pression (ft.)	Climb speed KIAS (km/h)	Rate of climb (ft./min) at 880 kg (1940 lb)		
		ISA	ISA + 10 °C	ISA + 20 °C
0	78 (145)	910	900	860
1000	78 (145)	910	900	860
2000	78 (145)	910	900	860
3000	78 (145)	910	900	860
4000	78 (145)	890	880	840
5000	78 (145)	860	850	820
6000	78 (145)	820	810	780
7000	78 (145)	790	780	750
8000	78 (145)	760	750	720
9000	78 (145)	720	720	690
10000	75 (139)	600	600	580
11000	75 (139)	570	570	570
12000	75 (139)	540	540	540
13000	72 (133)	500	500	500
14000	72 (133)	450	450	450
15000	72 (133)	400	400	400
16000	72 (133)	350	350	350

Table 5-5 - Rate of climb at 880 kg

Climb time, flaps retracted, 980 kg

Pressure altitude (ft.)	Climb speed kts (km/h)	Time (min)		
		ISA	ISA +10°C	ISA +20°C
0	78 (145)	0	0	0
1000	78 (145)	1,5	1,5	1,6
2000	78 (145)	2,9	3,0	3,2
3000	78 (145)	4,4	4,5	4,8
4000	78 (145)	5,9	6,1	6,4
5000	78 (145)	7,5	7,7	8,1
6000	78 (145)	9,1	9,3	9,8
7000	78 (145)	10,9	11,1	11,7
8000	78 (145)	12,7	13,0	13,7
9000	78 (145)	14,7	15,0	15,8
10000	75 (139)	16,8	17,1	18,1
11000	75 (139)	19,5	19,8	21,0
12000	75 (139)	22,6	22,9	24,1
13000	72 (133)	26,0	26,3	27,5
14000	72 (133)	30,1	30,4	31,6
15000	72 (133)	35,1	35,4	36,7
16000	72 (133)	41,4	41,7	42,9

Table 5-6 - Climb time at 980 kg (maximum take-off mass)

Climb time, flaps retracted, 880 kg

Pressure altitude (ft.)	Climb speed kts (km/h)	Time (min)		
		ISA	ISA +10°C	ISA +20°C
0	78 (145)	0	0	0
1000	78 (145)	1,1	1,1	1,2
2000	78 (145)	2,2	2,2	2,3
3000	78 (145)	3,3	3,3	3,5
4000	78 (145)	4,4	4,5	4,7
5000	78 (145)	5,5	5,6	5,9
6000	78 (145)	6,7	6,8	7,1
7000	78 (145)	7,9	8,0	8,4
8000	78 (145)	9,2	9,3	9,7
9000	78 (145)	10,6	10,7	11,1
10000	75 (139)	11,9	12,1	12,6
11000	75 (139)	13,6	13,8	14,3
12000	75 (139)	15,4	15,6	16,1
13000	72 (133)	17,3	17,4	18,0
14000	72 (133)	19,4	19,5	20,1
15000	72 (133)	21,7	21,8	22,4
16000	72 (133)	24,3	24,4	25,0

Table 5-7 - Climb time at 880 kg.

Maximum angle of climb, flaps in take-off position

Minimum 8.3% at sea level, in standard atmosphere, at maximum take-off mass and at 65 KIAS (120 km/h).

Glide performance

Engine off, the aircraft glides 9 times its height above the ground (with no wind) at 78 KIAS (145 km/h).

Altitude and temperature do not make a perceptible difference.

CRUISE PERFORMANCE

In standard atmosphere.

Range and endurance calculations include a 45 min reserve on arrival at the destination.

It is assumed that increased fuel consumption in the climb is offset by reduced consumption during descent.

Range is stated in nil wind.

Standard capacity.

Standard tank: 109 litres usable.

The capacity may be increased by an optional tank.

Standard tank + auxiliary tank: 159 litres usable.

Optional auxiliary tank 50 litres usable.

At the maximum take-off mass of 980 kg (2161 lb)

Pressure altitude (ft.)	Engine load %	Speed		Fuel consumption l/h	Standard tank 109 litres		Standard tank + auxillary tank 159 litres	
		KCAS	KIAS		Nm	hours	Nm	hours
2000	75	108	111	21,2	496	4,5	758	6,8
2000	70	104	107	19,6	516	4,8	788	7,4
2000	65	100	103	18,1	537	5,2	821	8,0
2000	60	95	98	16,7	555	5,7	848	8,7
2000	55	88	91	15,3	562	6,2	859	9,5
2000	50	79	81	13,9	554	6,8	846	10,4
<hr/>								
4000	75	107	114	21,2	508	4,5	776	6,8
4000	70	103	109	19,6	526	4,8	804	7,4
4000	65	99	105	18,1	548	5,2	837	8,0
4000	60	94	99	16,7	564	5,7	862	8,7
4000	55	87	92	15,3	570	6,2	871	9,5
4000	50	78	82	13,9	561	6,8	857	10,4
<hr/>								
6000	75	107	117	21,2	520	4,5	794	6,8
6000	70	102	112	19,6	537	4,8	821	7,4
6000	65	98	107	18,1	559	5,2	854	8,0
6000	60	93	101	16,7	576	5,7	880	8,7
6000	55	85	93	15,3	579	6,2	885	9,5
6000	50	76	84	13,9	569	6,8	870	10,4

Pressure altitude (ft.)	Engine load %	Speed		Fuel consumption l/h	Standard tank 109 litres		Standard tank + auxillary tank 159 litres	
		KCAS	KIAS		Nm	hours	Nm	hours
8000	75	106	120	21,2	533	4,5	815	6,8
8000	70	101	114	19,6	548	4,8	838	7,4
8000	65	97	109	18,1	571	5,2	872	8,0
8000	60	91	103	16,7	582	5,7	890	8,7
8000	55	84	95	15,3	587	6,2	897	9,5
8000	50	75	85	13,9	575	6,8	880	10,4
10000	75	105	122	21,2	545	4,5	833	6,8
10000	70	100	116	19,6	560	4,8	856	7,4
10000	65	96	112	18,1	582	5,2	890	8,0
10000	60	91	106	16,7	601	5,7	918	8,7
10000	55	83	97	15,3	598	6,2	915	9,5
10000	50	74	86	13,9	586	6,8	895	10,4
12000	75	104	125	21,2	557	4,5	851	6,8
12000	70	99	119	16,6	572	4,8	875	7,4
12000	65	95	114	18,1	595	5,2	909	8,0
12000	60	90	108	16,7	613	5,7	937	8,7
12000	55	82	98	15,3	610	6,2	933	9,5
12000	50	73	88	13,9	596	6,8	912	10,4

Table 5-8 - Cruise performance at 980 kg (2161 lb)

LANDING PERFORMANCE

At the maximum take-off mass of 980 kg (2161 lb),
No wind, flaps in landing position, engine idle.
Runway hard, dry and flat.

ALTITUDE	TEMPERATURE		MASS 980 kg (2161 lb)				
	ft. (m)	°C	°F	Ground roll		Landing distance from passing 15 m (50 ft.)	
				m	(ft.)	m	(ft.)
0	- 5	23	266	873	479	1570	
	Std=15	59	282	925	507	1663	
	35	95	298	976	535	1755	
2000 (610)	-9	16	277	909	498	1635	
	11	52	294	964	528	1733	
	31	88	310	1018	558	1830	
3000 (914)	-11	12	284	931	510	1674	
	9	48	301	987	541	1775	
	29	84	318	1043	572	1875	
4000 (1219)	-13	9	291	953	527	1728	
	7	45	308	1011	559	1833	
	27	81	326	1069	591	1937	

Table 5-9 - Landing performance

Influence of head wind:

- for 10 KIAS, multiply by 0.85
- for 20 KIAS, multiply par 0.65
- for 30 KIAS, multiply by 0.55

Influence of tail wind:

- add 10 % for each 2 KIAS of tail wind.

Dry grass runway:

- add 15 %.

Sloping runway:

- A downward slope of 2% (2m in 100m) increases the landing distance by about 10%. The effect on the ground roll may be greater.

PAGE INTENTIONALLY LEFT BLANK

SECTION 6 :

MASS AND BALANCE

The nomogram that follows is used to determine the balance of the DR400.

- ◆ Note : Diesel and JET fuels are more dense than AVGAS and so have a greater mass for the same volume. Because of the rearward position of the fuel, as the fuel is used, the centre of gravity moves forward.

For a given amount of fuel, the turbo diesel powered DR400 has better range and, at altitude, higher speed than the Robin aircraft fuelled with AVGAS and having the same performance at sea level.

- ◆ Note : If the supplementary fuel tank is fitted, it is necessary to be sure that there is sufficient space in the main tank to take all the fuel contained in the supplementary tank before transferring the fuel from the supplementary tank into the main tank.

The pilot must ensure that the aircraft is correctly loaded.

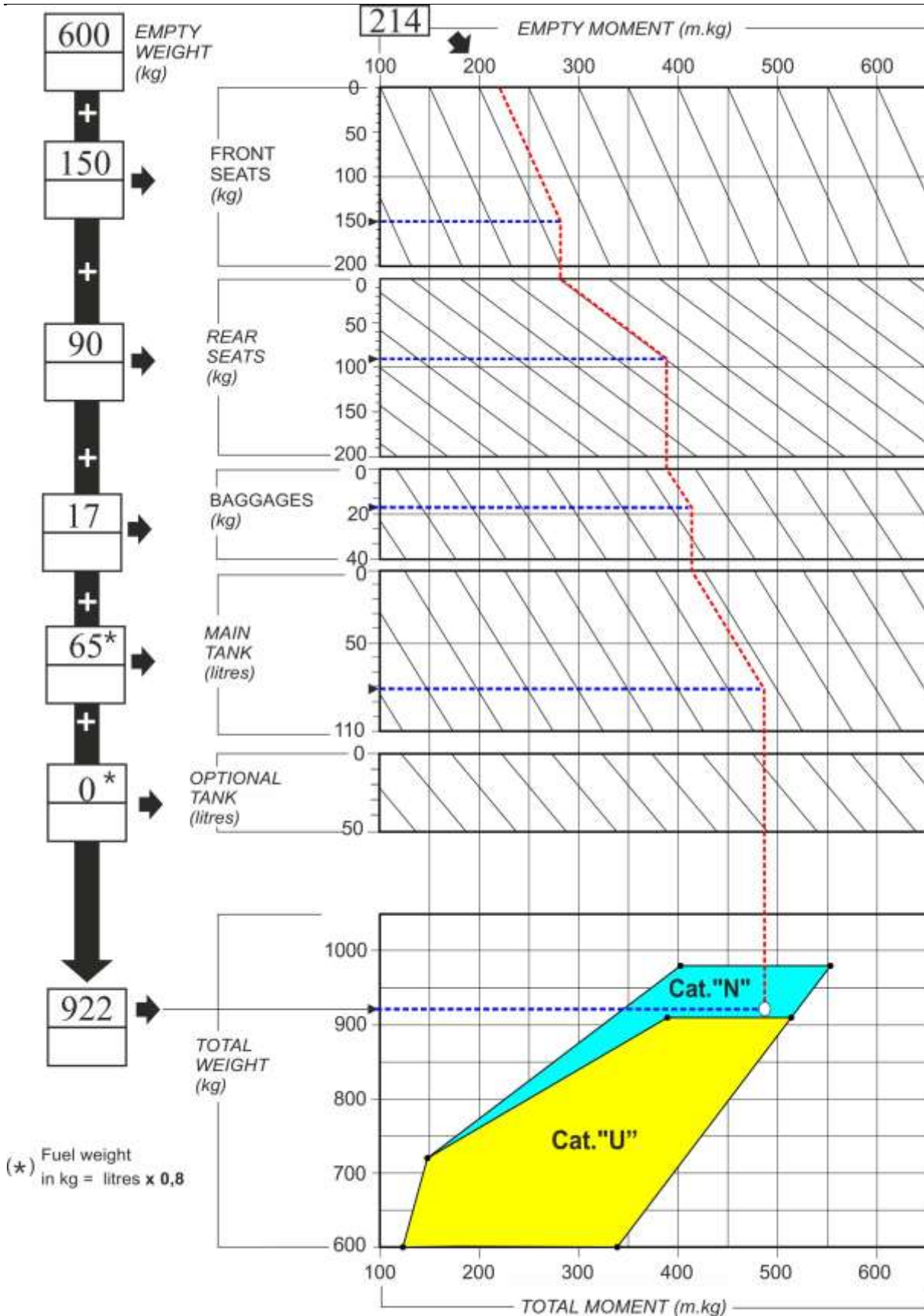

Figure 6-1 - Mass and balance.

USE OF THE NOMOGRAM

- 1) Calculate the total weight of the aircraft:
 Empty weight (see the weighing sheet)
 + weight of pilot and passengers
 + weight of luggage
 + fuel (1 litre JET A1 = 0.840 kg)
 Ensure that the total weight does not exceed 980 kg (2161 lb) for category N and 910 kg (2006 lb) for category U.

- 2) Enter the empty weight of the aircraft (see the weighing sheet) in the appropriate box of the nomogram, then enter your data according to the example, extending the dashed lines as appropriate.

The final point must be within the relevant mass-moment area for the loading to be acceptable.

EXAMPLE of loading calculation (dotted lines on the diagram)

Empty weight moment (for example)	(1548 ft.lb) 214 m.kg
Empty weight.....	(1322 lb) 600 kg
Pilot + front seat passenger	(331 lb) 150 kg
Rear seat passenger	(198 lb) 90 kg
Fuel ≈ 77.4 l (21.2 US gal)	(143 lb) 65 kg
Luggage	(37.5 lb) 17 kg

TOTAL WEIGHT(2032 lb) 922 kg

Balance: within the prescribed limits.

1 litre JET A1	0.8 kg (1.76 lb)
1 US gal JET A1	3 kg (6.61 lb)

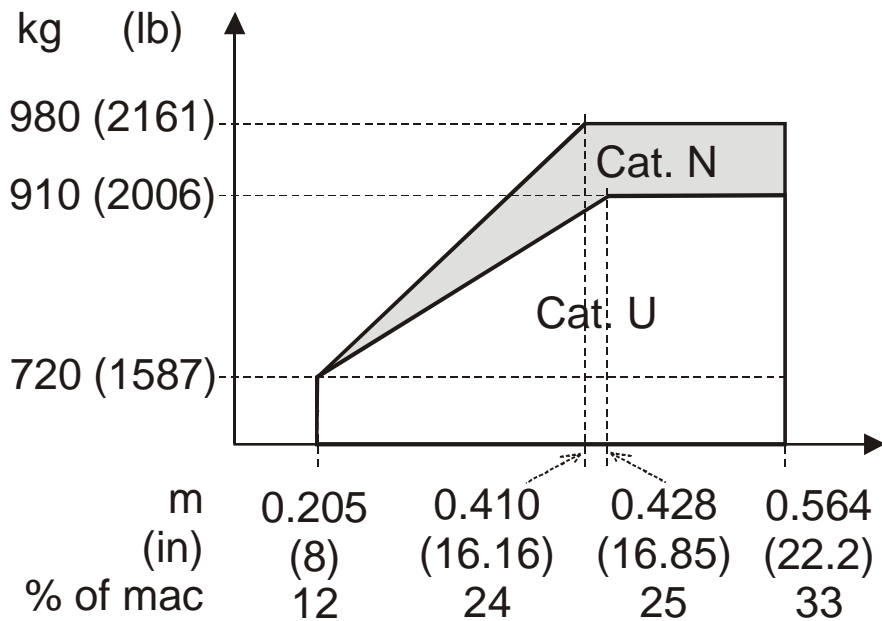

Figure 6-2 - Mass and balance graph

▲ ATTENTION : In calculating the balance of your aircraft, **do not use** the values of empty weight and empty moment given in the preceding example!
Instead, use the values from the latest weighing sheet for your aircraft.

SECTION 7 :

DESCRIPTION OF THE AIRCRAFT **AND ITS SYSTEMS**

This section provides a description of the basic operating procedures for the standard aircraft and its systems. The optional equipment described in this section is identified as optional.

- ◆ **Note :** Some optional equipment, particularly avionics systems, may not be covered in this section. For descriptions and procedures not described in this section, refer to SECTION 9: « **Supplements** ».

Airframe

The DR400 is a four seat, single-engine, low-wing, monoplane aircraft with wing-tip dihedral, a one-piece horizontal stabilator and a fixed tricycle landing gear. The structure is mainly of reinforced or covered wood. Some parts are made of laminated composites, or aluminium alloys. The mechanical sub-assemblies are generally made of steel.

Flap control switch

The flaps are controlled by a multifunction unit, which actuates an electric jack and controls the annunciator lights.

The control switch has three positions (retracted, take-off and landing). The take-off position is indicated by the middle green light.

The landing position is indicated by the middle and the bottom lights.

When the flaps are retracted, all the lights are extinguished.

The lights flash when the flaps are moving.

The system is protected by a specific circuit breaker.

At power-up, the system runs a self-test:

If the red light remains illuminated then there is a fault. In this case, disconnect and then reconnect the circuit breaker to reset the system. If the fault persists, contact your maintenance organisation.

The system can also be reset in flight if the red light comes on.

Elevator system

The elevator control transmits movements to the stabilator by means of cables directly connecting the stick to an articulated joint (of monobloc type).

Aileron system

The ailerons are controlled directly by cables attached to the stick.

Rudder control

The rudder is turned by cables connected directly to the rudder pedals.

Control lock

The DR400 is not equipped with a control lock. If parking outside, it is advisable to prevent aileron and rudder movement by securing the **pilot's seat belt** around the stick.

Elevator trim

The elevator trim consists of an electric jack connected to the trim tab, a control switch and a position indicator on the centre console, and a circuit breaker.

A control switch is on both the pilot's and the co-pilot's stick.

Roll compensation

Roll adjustment can only be done in the workshop by fitting a trim tab under one aileron. The system is set for cruise at 75% power.

Yaw compensation

The yaw adjustment can only be done in a workshop by adjusting the rudder control cable tensioners. The basic setting is made for a cruise at 75% power.

Cabin layout

The following paragraphs give a general description of the cabin, the instruments and the controls. Details of the instruments, switches, circuit breakers and controls on the upper and lower and annunciator panels, and the central console are given in the supplement for the panel of the specific aircraft.

Panel and centre console

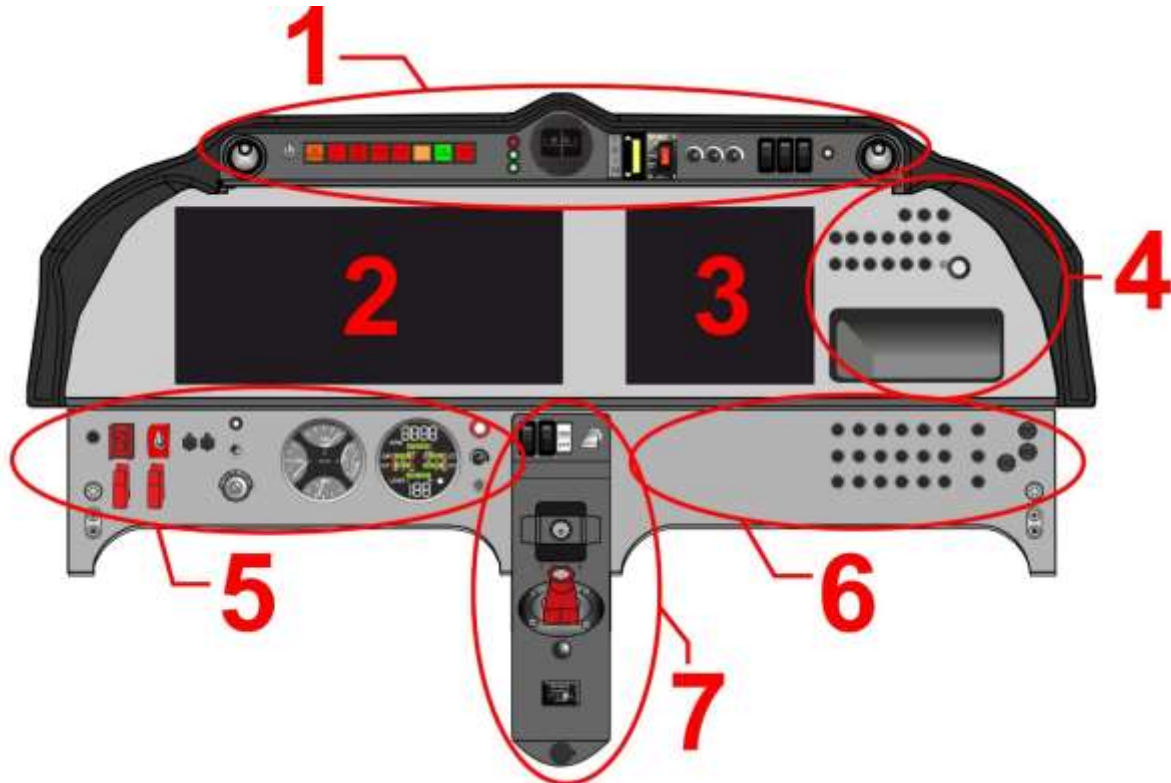

Figure 7-1

- Part 1 = upper panel (ventilator / lights / compass / ELT)
- Part 2 = flight instrument area (according to the equipment specified)
- Part 3 = area for radio / navigation equipment
- Part 4 = circuit breakers and storage box
- Part 5 = engine instruments
- Part 6 = area for radio / NAV, circuit breakers
- Part 7 =
 - Controls for fuel pump, landing and taxiing lights, flaps
 - Controls for engine and propeller
 - Fuel selector valve
 - Parking brake control
 - Hour meter
 - 12 V supply socket

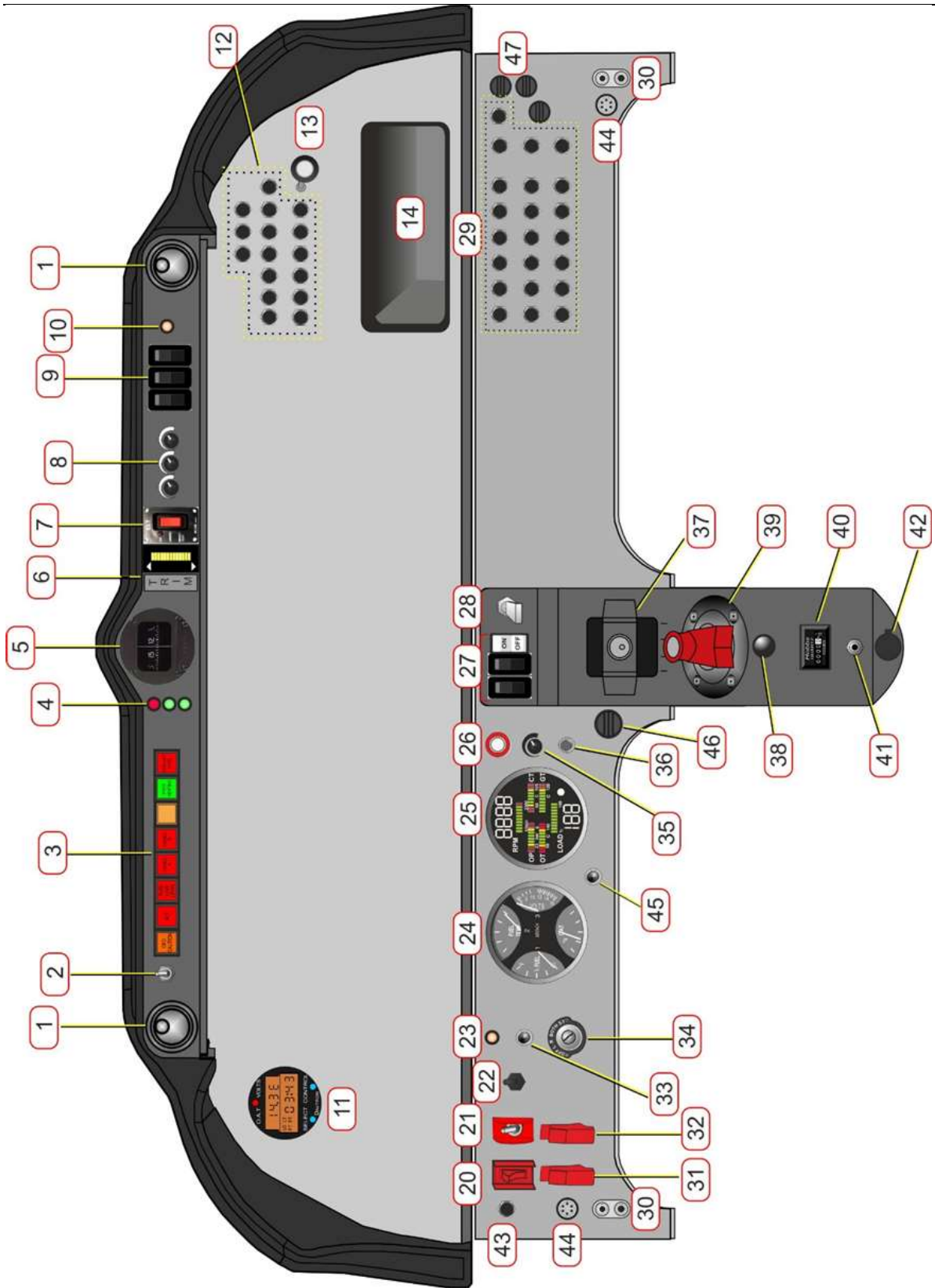

Figure 7-2 Panel

◆ Note: Refer to the panel supplement (SECTION 9) for the avionics and radio layout.

Pos	Fonction	Pos	Fonction		
1	Adjustable ventilators	24	Quad guage (clockwise from top): Fuel volume Voltmeter OAT Fuel temperature		
2	Light test and day/night brightness				
3	Annunciator lights: CED warning Alternator charge Low fuel level FADEC A FADEC B Not in use Pitot heat (option) Low coolant level			25	Compact engine display (CED)
				26	Alternate air
		27	Switches: Landing light Taxiing light Electric fuel pump		
				28	Electric flap control switch
				29	Circuit breakers
4	Flap indicator lights	30	Microphone / headphone jacks		
5	Magnetic compass	31	Alternator relay switch		
6	Elevator trim indicator	32	Force FADEC B switch		
7	ELT switch			33	FADEC test
				34	Key operated starter switch
				35	CED backlight control
8	Panel lighting controls: - 1: Under glare shield - 2: directional ceiling light - 3: radio and instruments	36	CED test / FADEC alarm reset		
		37	Engine power lever		
		38	Fuel valve		
		39	Parking brake control lever		
9	Switches: Strobe Navigation lights Pitot heat (option)	40	Hour meter		
		41	Audio jack (option)		
		42	12V power socket (option)		
		43	Alternator circuit breaker		
10	Flight recorder indicator light (option)	44	LEMO sockets (option)		
11	Clock / stopwatch	45	Push-button for auxillary tank fuel volume and temperature		
12	Avionics circuit breakers				
13	Cabin heat lever	46	Auxillary fuel tank transfer control		
14	Storage box	47	Heating/demisting controls		
20	Battery master switch				
21	Engine master switch				
22	Avionics master switch				
23	Glow plug indicator				

Table 7-1 Index for panel, figure 7-2

« tri gauge » and « quad gauge » instruments

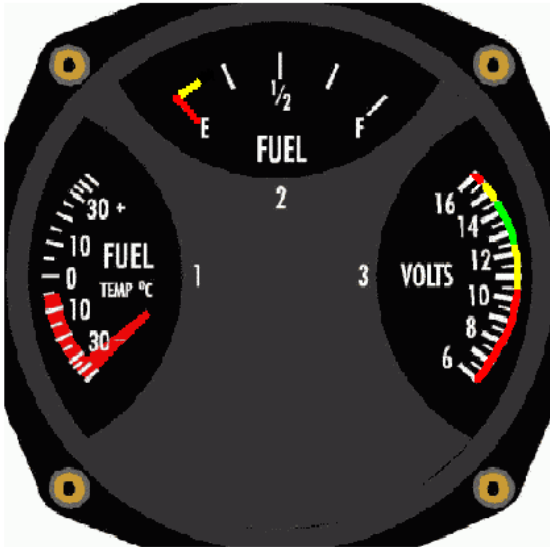

Example of Westach "tri gauge", without OAT



Example of Westach "quad gauge", with OAT

Canopy

The canopy opens by sliding forward allowing access to the seats. To prevent the canopy striking the oil filler hatch, ensure the hatch is closed and locked before moving the canopy.

The operating handle is located at the top, in the centre of the canopy. The exterior part of the handle is fitted with a key-operated lock.

The interior part of the handle is accessible by the pilot and the co-pilot.

In case of need, the canopy is equipped with a release system consisting of two levers located on the armrests, either side of the panel.

The levers release the canopy from its rails, allowing it to be lifted free.

Seats

The DR400 is equipped with seats that simultaneously adjust for height and reach by means of a lever (labelled '1' in figure 7-3) situated at the front left of the pilot's seat and the front right of the co-pilot's seat.

There are four different positions, from the lowest and furthest from the panel to the highest and nearest.

Whilst supporting your weight on the handle attached to the armrest and the panel using your outboard hand, move the seat control lever from right to left for the pilot seat or from left to right for the co-pilot seat with the other hand. Then pull forward or let back using the armrest handle to make the adjustment.

The seat control levers also allow the front seats to be tilted fully forward to give access to the rear seats.

A ring located at the rear of the front seats (labelled '2' in figure 7-3) allows the rear seat occupants to tilt the front seats fully forward.



Figure 7-3 (pilot's seat frame)

Seat belts

There is 2 different systems:

System n°1: On aircrafts before serial number n°2718

The belts for the front seats consist of three straps, two of which are adjustable and one of which is tensioned by a retractor (see figure 7-4) (optional for the rear seats).

Clip the shoulder strap (labelled 1) onto the stud (labelled 2) of the belt, and then lock the eye (labelled 3) into the buckle (labelled 4). Then tighten the two straps.

Lift the buckle (labelled 4) to release the belt.



Figure 7-4 (Example: pilot's [left side] belt)

System n°2: On aircrafts since serial number n°2718.

This system consists of a single harness with retractor, to fulfill the functions of ventral belt and shoulder. 3-point belt with car buckle.



Figure 7-5 (Harness example)

Luggage compartment

The luggage compartment of the DR400 is behind the rear seats. It is accessible from the outside by a door secured by two, key-lockable, compression latches.

The hatch is unlocked by pressing the push-buttons (labelled 1 in fig 7-5) of each latch, after which the door is opened upwards.

The hatch is held open by means of a self-locking strut.

To close the hatch, pull forward on the hinge of the strut and let the door down. Then actuate the push-buttons to compress the seal and lock the latches.

It is recommended that both latches are locked by key before flight.

The baggage compartment floor is fitted with four elastic ropes for securing the luggage.

During flight, the luggage must be evenly distributed in the compartment so as to maintain the balance of the aircraft and must be secured using netting or straps attached to the fixing eyes on the compartment floor.

It is imperative to check the total weight and the centre of gravity of the aircraft when carrying luggage.

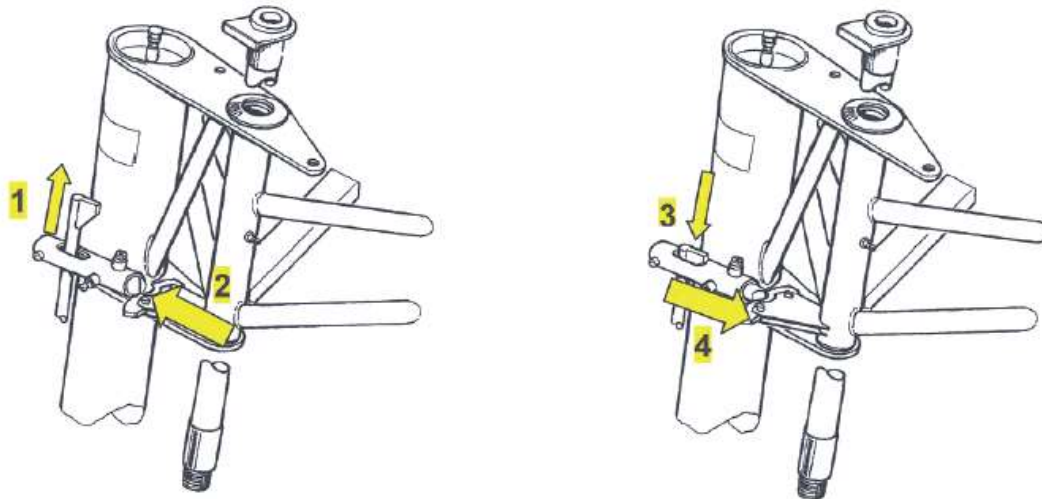

Figure 7-5 Compression latch

Landing gear

The DR400 is equipped with a fixed tricycle landing gear with oleo-pneumatic dampers, with the front wheel steerable using the rudder pedals. The nose gear is equipped with an anti-shimmy device.

The nose gear is equipped with a locking system that keeps the wheel in the axis of the aircraft during flight and allows steering on the ground.



On the ground: unlocking the nose gear.

The compression of the nose damper during the run (parking, landing) causes the rise of the cam (1). This action release the finger (2) which move back and leave the groove of the paddle of the engine frame and releases the nose gear.

In flight: locking the nose gear.

The expansion of the nose damper during the take-off or the flight causes the descent of the cam (3) into the housing. This action pushes the finger (4) into the groove of the paddle of the engine frame and immobilizes the nose gear.

Braking system

The brake master-cylinders are secured against the inside of the firewall by a bracket on which the parking brake valve is also fixed. The master-cylinders are actuated by hinged tubes located in the angle between floor and firewall and controlled by connecting rods attached to the pedals. Each brake (right or left) is operated independently from the pilot's or the co-pilot's position.

Braking is independent of steering.

Parking brake

The aircraft is equipped with a parking brake which allows pressure to be maintained in the master cylinders, thus locking the wheels.

When the aircraft is stationary, depress the brake pedals and maintain pressure. Pull the parking brake plunger and then release the pedals. The parking brake is now actuated.

To release the brake, simply push the plunger downwards.

- ▲ WARNING:** Do not pull the parking brake plunger during flight. In the event of landing with the parking brake valve engaged, any braking force applied using the pedals will be maintained even if the pedals are released. This can lock the wheels and cause a tyre burst or a fire.

Use of the brakes

The braking system of an aeroplane is not intended to be permanently activated. To prevent the system overheating, it is important to:

- During the pre-flight inspection, make sure that the braking system is not seized.
- Taxi using minimum power. Once in motion, on hard ground, idle power should be sufficient to keep the aircraft moving. The need to continuously taxi with power can indicate a problem (brake binding, residual pressure in the brake system, low tyre pressure...).
- Do not taxi with power and control the speed with the brakes.
- Be careful not to apply permanent pressure on the top of the pedals (thus applying the brakes). Lower your feet so as not to activate the brakes continuously.
- Brake intermittently rather than continuously to allow the brakes to cool between applications.
- Taxi at a moderate speed; it is safer both for you and for other users of the airfield.

Engine

The TAE 125-02-099 is a four-stroke, 4 cylinder in-line diesel engine with double overhead camshafts, liquid cooled and with common rail direct fuel injection. It has a cylinder volume of 1991 cm³. The engine is managed by a FADEC system. The engine is equipped with an electric starter and an alternator.

- ▲ **WARNING:** The engine requires an electrical supply to operate. If the main battery and the alternator fail simultaneously, the engine will continue to run for a limited time using the FADEC backup battery. It is, therefore, important to pay attention to symptoms of alternator failure.

Engine parameter indicator CED-125



Figure 7-6 Detail of CED-125

Propeller

The aircraft is fitted with an hydraulically controlled, constant speed, variable pitch propeller.

The propeller is driven through a reduction gearbox equipped with a vibration damper and overload protection.

The pitch and rotational speed of the propeller are maintained by oil pressure, which is controlled by an ECU regulated by the « Constant Speed Unit ».

An internal spring returns the propeller pitch to fine (RPM maximum), whilst the oil pressure controlled by the regulator causes the propeller pitch to coarsen (RPM minimum).

The regulator uses gearbox oil to control the propeller.

■ **CAUTION:** Do not move the aeroplane by pushing on the spinner.

Electrical system

The electrical system of the TAE 125 installation is equipped with the following displays and:

1. Battery master switch:
The battery must be connected for normal operation.
2. Alternator switch:
Turns the alternator off. The alternator must be left “on” during normal operation.
3. “Starter” key:
This switch only controls the electric starter motor.
4. Voltmeter.
5. Alternator warning light:
Illuminates if the output voltage of the alternator is too low, too high or when the « Alternator » circuit breaker is off. This warning light is normally illuminated when the engine master switch is on but the motor is stopped. It should extinguish immediately the engine has started.
6. Engine master switch :
Via three independent contacts, the engine master switch controls the two duplicate FADEC units and the backup battery that excites the alternator.

It is protected against unintentional activation by a secure mechanism (*pull-to-actuate*) and a guard. The alternator excitation backup battery is there to ensure that the alternator always operates, even if the main battery fails.

▲ **WARNING:** If the engine master switch is turned off, the FADEC power supply is interrupted and the motor will stop.

7. "FORCE B" switch:

If the FADEC system does not automatically switch from FADEC A to FADEC B in the case of need, the "Force B" switch allows FADEC B to be selected manually.

▲ **WARNING:** When operating on the FADEC backup battery, the "FORCE B" switch must not be used. This action would stop the engine.

8. FADEC backup battery:

The backup battery only supplies power to FADEC A when the power supply from the main battery and the alternator is interrupted. This will keep the engine running only for a limited time.

Electrical circuit

See the maintenance manual.

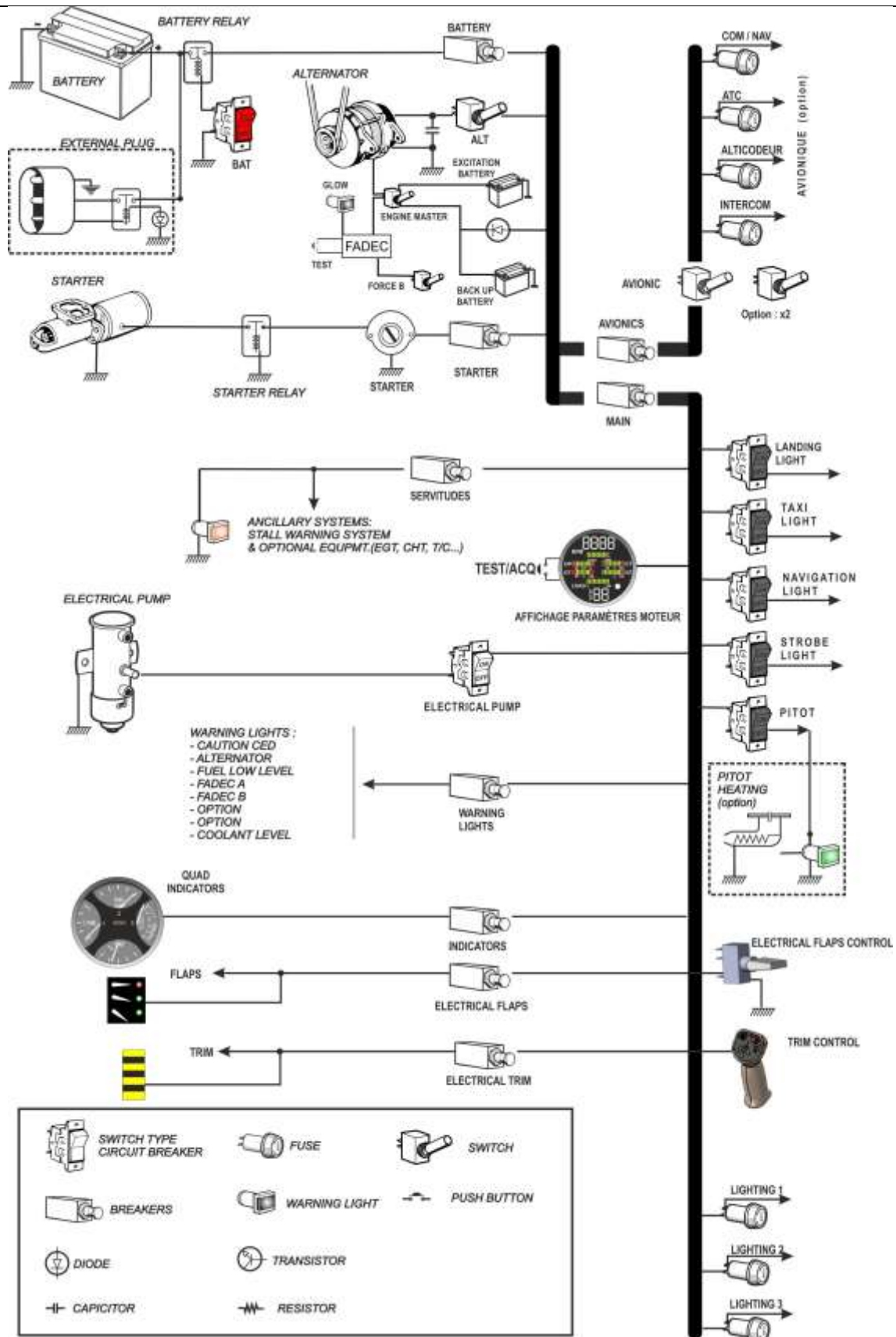

Figure 7-7 Simplified circuit diagram

Re-initialisation of FADEC

In the event of a FADEC alarm, one or two FADEC warning lights will flash. If the FADEC test button is then pressed for at least two seconds:

- a) The warning lights will extinguish in the case of a LOW category alarm.
- b) The warning lights will stay on permanently in the case of a HIGH category alarm.

▲ WARNING: When a FADEC alarm has occurred, contact your service centre. Flights are not allowed.

When a HIGH category alarm occurs, the pilot must land as soon as possible at the nearest available airfield, as the affected FADEC has diagnosed a major failure. A LOW category alarm has no impact on the operation of the engine.

See the operating manual OM-02-02 for more information.

Fuel / Fluids

Approved fuels and fluids are listed in « SECTION 2 – limitations » of this flight manual.

▲ **WARNING:** Under no circumstances should the engine be started if a level is too low.

▲ **WARNING:** Testing the fuel is essential before each flight and after each refuelling to ensure that there are no impurities nor water in the tanks.

Because of their high pressure pump, diesel engines are particularly sensitive to the presence of water.

To perform a reliable test the aircraft must be on a horizontal surface and have been immobile for about 30 minutes.

The sample must be taken in a clean container intended for the purpose and which allows the identification of impurities and water.

If, after repeated sampling, evidence of contamination still exists, the airplane should not be flown. All evidence of contamination must be removed before further flight.

▲ **WARNING:** Ensure the fuel is of the correct type (Diesel or JET-A1 and not AVGAS: the colour must not be blue).

■ **CAUTION:** Use of unapproved fuels can cause damage to the engine and fuel system, eventually resulting in engine failure.

■ **CAUTION:** It is not normally necessary to supplement the levels of coolant or gearbox oil between routine maintenance operations. If the level is low, contact your maintenance organisation immediately.

Engine Oil

The engine is equipped with a wet sump oil system for engine lubrication and cooling.

The oil is drawn from the sump by the pump and is passed to the filter, then to the thermostat.

When the oil temperature is below 78°C, it is short cycled. When the temperature passes 78°C, the thermostat opens the circuit to the oil cooler. At temperatures greater than 94°C, the oil passes only through the oil cooler, which ensures a maximum oil temperature of 140°C under all operating conditions.

The temperature and pressure of the oil are displayed on the CED 125 and are monitored by the FADEC.

The system contains 4.5 to 6 litres of oil (1.19 to 1.59 US GAL); the level can be checked with the dipstick.

Fuel system

The fuel system includes a main tank supplying the engine, with a fuel return, a tank fuel level sensor with display and an independent low fuel level alarm. A sensor and fuel temperature display are also installed.

The 110 litre main tank is located under the rear seats. Fuel is sent to the fire stop valve, situated under the floor, by the electric pump. The fuel then continues to the mechanical pump.

Fuel flows from the tank to a valve that has two positions: OPEN and CLOSED.

The electric pump maintains flow to the fuel filter if necessary. Upstream of the fuel filter is a thermostatically controlled fuel pre-heater. The mechanical pump and the high pressure pump then feeds the common rail from which the fuel is injected into the cylinders according to the position of the power lever (throttle) and FADEC control.

Excess fuel returns to the filter and then to the tank via the valve. A temperature sensor in the filter module manages the heat exchange between the fuel supply and the fuel return. Diesel fuel tends to form paraffin precipitates at low temperature: the instructions in section 2 « Limitations » regarding the fuel temperature must be followed. Returning pre-heated fuel to the tank ensures faster heating of the fuel.

If diesel fuel is used, it must comply to **DIN EN 590**.

◆ **Note :** Depending on the country, there may be several different prefixes for EN 590. Only fuels with the prefix **DIN EN 590** are approved.

Fuel volume			
Tank	Total consumable fuel	Total non-usable fuel	Total volume
	109 litres	1 litre	110 litres
	28.7 US gal	0.26 US gal	29 US gal
	24 imp gal	0.22 imp gal	24.2 imp gal

Table 7-2 Fuel volume

The total fuel capacity can be increased to 160 litres (35.2 Imp gal / 42.24 US gal) or 159 litres usable (35 Imp gal/42 US gal) by the installation of an optional tank of 50 litres (11 Imp gal / 13.2 US gal).

Optional tank

The optional 50 litre tank feeds into the main tank. A valve directly attached to the outlet of the optional tank is controlled by a plunger on the panel. The optional tank is installed in the fuselage behind the rear seat. The fuel in the optional tank is transferred to the main tank by pulling the plunger situated on the panel.

The optional tank's fuel temperature and level are displayed on the tri gauge or quad gauge (depending on the panel configuration) when the push button is pressed.

▲ **WARNING:** The optional tank has a fuel level gauge but does not have a low fuel level alert.

▲ **WARNING:** The optional tank is only approved for JET-A1.

◆ **Note :** The main tank must have sufficient space to receive all the contents of the supplementary tank before starting to transfer fuel.

The optional tank is not heated. It is restricted to the use of Jet-A1 to avoid the risk of solidification of the fuel at low temperatures.

Fuel level gauges

The supplementary tank (if fitted) and the main tank are fitted with fuel level sensors that display on the tri gauge or quad gauge (depending on the configuration of the panel).

The default indication is for the main tank, data for the supplementary tank is displayed when the push-button is pressed.

- ◆ **Note :** Indicating the fuel level presents a complex problem because the fuel moves within the tanks. The fuel shifts in turbulence and as the aircraft is manoeuvred.
Always check that the fuel on board is adequate for your flight. The use of the gauges does not absolve the pilot from good pre-flight planning, pre-departure checking of the levels, and in-flight fuel monitoring.

- ◆ **Note :** The indication of fuel levels in the tanks is only reliable when the aircraft is stable, wings level, and in balanced flight.

Tank selector

The fuel tank selector (and fire valve) is located on the centre console. A locking / unlocking action is needed to move the selector to and from the « off » position (pull up on the button over the valve control before turning the control).

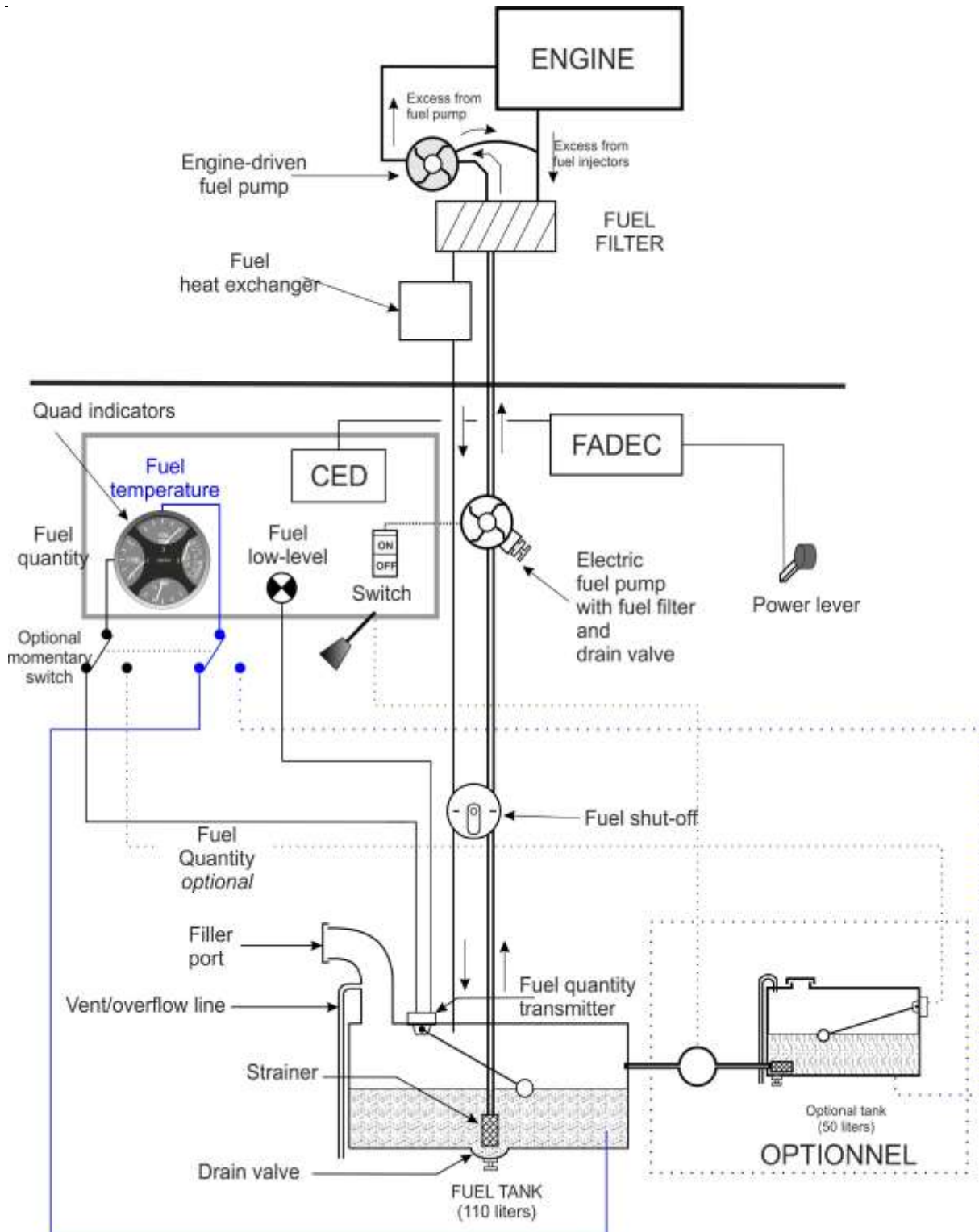

Figure 7-8 Simplified diagram of the fuel system

Heating and ventilation

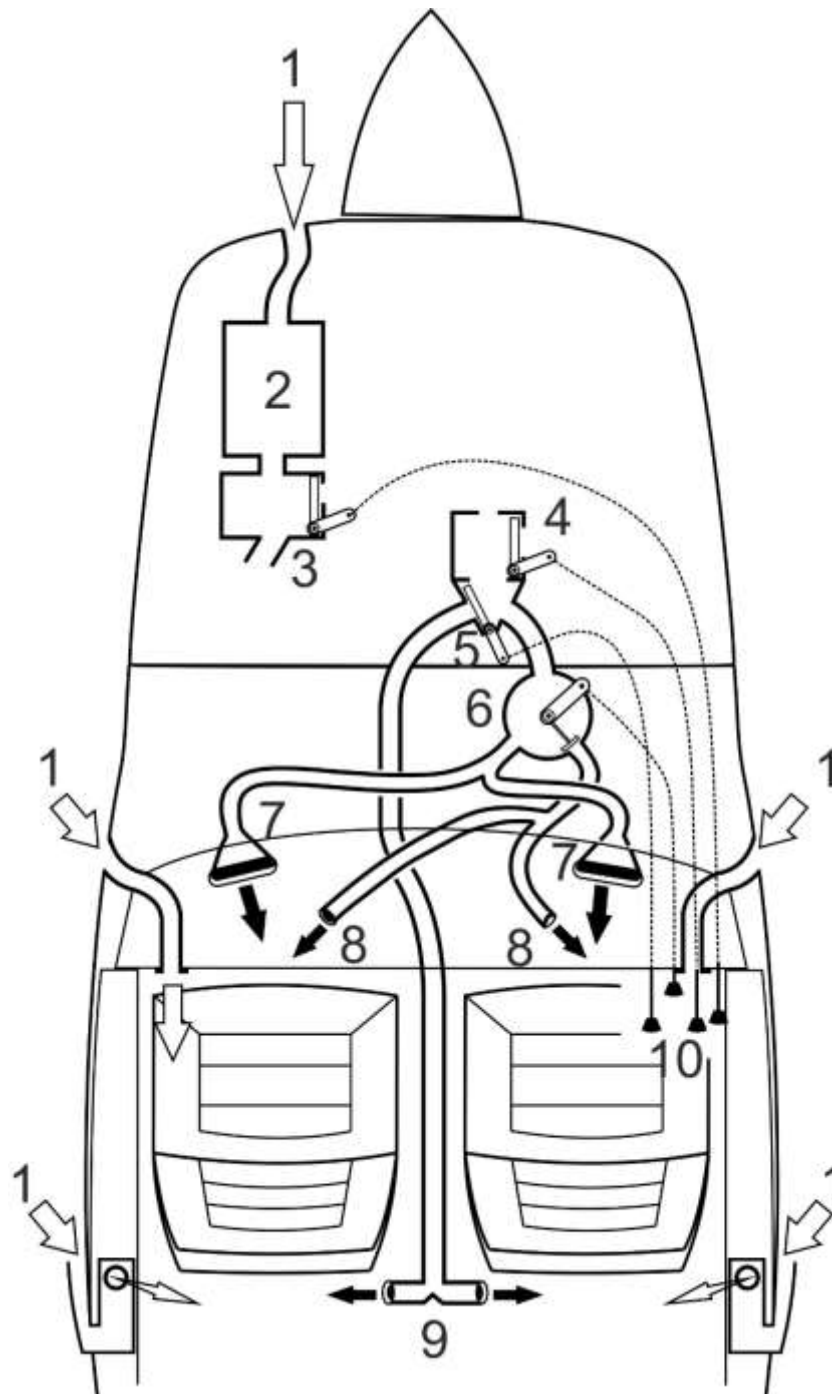

Figure 7-9 Heating and ventilation

- | | |
|----------------------------|-------------------------------------|
| 1 Fresh air intakes | 2 Heat exchanger |
| 3 Hot air distribution box | 4 Hot air master control box |
| 5 FRONT / REAR selector | 6 Heating / demisting selection box |
| 7 Windshield demisting | 8 FRONT heating |
| 9 REAR heating | 10 Push / pull heating controls |

Function of heating/demisting plungers			
	Function	Pull	Push
Control 0	Heat	On	Off
Control 1	Heat	On	Off
Control 2	Heating / demisting	Front heating	Windshield demist
Control 3	Front / rear selection	FRONT	REAR

Table 7-3 - Heating control positions

- ◆ **Note :** Distribution according to the need for front/rear heating and demisting can be achieved by adjusting the positions of controls 2 and 3.

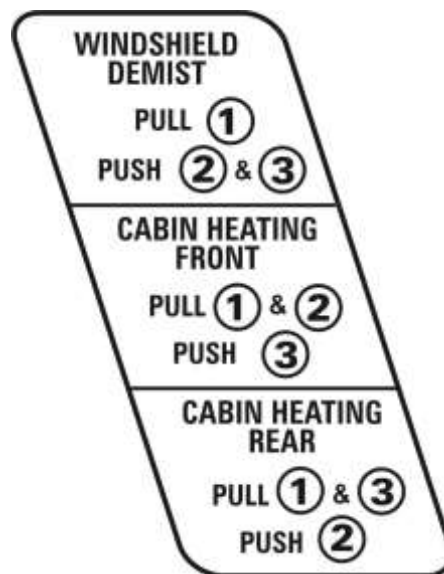

Figure 7-10 Heating control label, right side of cabin.

The TAE engine installation has a fourth control (control 0 in table 7-3). It must be closed (pushed) when cabin heating is not required (ambient temperature is sufficient).

Lighting (optional)

Optionally, the aircraft can be equipped with:

- Wingtip lights that combine navigation and strobe lights;
- Taxiing and landing lights in the left leading edge of the wing;
- Adjustable interior lights (panel, instruments and cabin).

Stall warning system

The aircraft is fitted with a stall warner that operates by detecting angle of attack. Whatever the configuration of the aircraft, the stall warner will trigger between 5 and 10 kts before the stall.

Pitot and static systems

The airspeed indicator, the vertical speed indicator and the altimeter all rely on the pressure system (for static pressure: 2 ports situated on either side of the fuselage; and for dynamic pressure: "PITOT", positioned under the wing on the left side of the aircraft).

The aircraft may be fitted with an optional pitot heater.

Avionics and navigation

The instruments installed depend on the configuration chosen. Refer to section 9 « Supplements » for specific items.

An avionics switch allows all the avionics equipment to be switched off together. This switch can be duplicated, in which case activating either will turn the avionics on or off. If one switch fails, the other will always operate (they are connected in parallel). When the switch is duplicated, only one switch must be turned ON.

Headset and microphone installation

The aircraft is equipped with microphone and headset jacks for each person. Optional, panel powered « Bose » (Lemo) jacks can be installed. A loudspeaker is located in the ceiling of the cabin to allow listening without headphones.

Flight recorder (optional equipment)

Safety Plane System

The aircraft is equipped with a flight recorder that registers the flight parameters. Its operation is automatic and it does not need user intervention.

The system has a LED to indicate its operation, located on the upper panel, and a dedicated circuit breaker on the middle or lower panel.

These components are labelled: « SafetyR ».

- ◆ **Note :** If the LED light remains on after the engine has started then this implies a malfunction of the Safety Plane **but the safety of the flight is unaffected.**

In the event of a malfunction, see document 1002560 *Flight recorder user manual associated with the Robin airframe warranty* for a description of actions to be taken.

For other information, refer to the manufacturer's documentation.

Emergency locator transmitter

The aircraft is equipped with an autonomous emergency locator transmitter (ELT). The radio beacon and the antenna are located immediately behind the rear bulkhead of the cabin, to the left of the aircraft axis.

The main switch of the beacon, marked 'on', 'off', 'armed' (ON-OFF-ARMED) is in the 'armed' position for normal operation. A remote control and an indicator panel are mounted on the upper panel. The radio beacon is mounted longitudinally in the aircraft and will detect a deceleration of greater than 3.5 ft/s. If a rapid deceleration is detected, the radio beacon transmits on the VHF band, alternately at 121.5 MHz and 406.0 MHz, approximately every 0.5 seconds.

Hour meter

The hour meter, mounted as standard, is located on the rear part of the centre console. It counts whenever the engine is running and totals the hours of operation of the engine.

Although fitted as standard, the hour meter is not mandatory equipment and, on request, it may be omitted during the building of the aircraft.

External power socket

The aircraft may be fitted with an optional external power socket located on the right side of the fuselage behind the wing.

The connection of a ground power unit to the power socket allows the following operations:

- Engine start;
- Demonstration of the electrical systems (eg the avionics) without draining the main battery;
- Recharging the battery.

Connection of an external power source allows power to be fed directly to the main battery (the external power socket is in parallel with the battery).

- **NOTE:** The electrical circuit of the aircraft is 14V continuous. Ensure that the external power supply provides regulated DC power at 14V.

Start-up / cockpit demonstration

Start-up and cockpit demonstrations are performed as if using the aircraft's battery.

Recharging the aircraft's battery

The connection of an external power source allows power to be supplied directly to the main battery. Connection of a suitable « charger » enables the main battery to be charged.

- ▲ **WARNING:** When replacing the aircraft's battery, pull the starter breaker as a precaution.
- ▲ **ATTENTION :** If the main battery is not able to start the engine independently, perform the necessary maintenance to ensure an operational battery.

PAGE INTENTIONALLY LEFT BLANK

SECTION 8 :

MAINTENANCE OPERATIONS

Introduction

This section provides general guidelines for servicing the DR400. To ensure the safe and efficient operation of the aircraft, it is necessary to maintain contact with the authorised service centre of the aircraft to obtain the most recent relevant information.

Publications for the user

The approved flight manual is supplied with the aircraft, and is available for download with subscription.

Maintenance publications

Maintenance publications are available on subscription.

Towing

On the ground, the aircraft can be moved using a tow bar that is stored in the luggage compartment. To engage the tow, insert it into the tube on the left side of the front wheel.

In case of resistance, if the nose gear steering is locked, apply moderate pressure on the root of a propeller blade (do not push on the spinner), or lift the fuselage under the tail using skip blade. If the nose wheel does not unlock then desist and consult the engineer in charge of maintenance.

Parking

The aircraft must be parked so as to protect it from the weather and to prevent it becoming a risk to other aircraft. The parking brake can release spontaneously or cause stresses due to overheating during braking or during large temperature changes. It is, therefore, necessary to secure the aircraft if it is left unattended or outdoors overnight.

- Park the aircraft nose to wind if possible;
- Retract the flaps;

- Lock the stick using the pilot's seat belt;
- Chock the main wheels.
Do not apply the parking brake for prolonged parking.
- Secure the aircraft according to the procedures in this section;
- Fit the pitot cover and insert the static pins;
- Lock the canopy and the luggage compartment;
- Fit a canopy cover.

Long-term parking

The aircraft must be parked in a way that ensures that it is immobile, safe and protected.

- Orientate the aircraft nose to wind if possible;
- Retract the flaps;
- Chock the wheels;
- Attach tie-down ropes to the wing and tail tie-down rings at an angle of approximately 45° to the ground. If using non-synthetic rope, leave sufficient slack to avoid damage to the aircraft if the ropes shrink.

Cleaning

Cleaning the exterior surfaces

- ◆ **Note :** Before cleaning, position the aircraft in a shaded area to keep the surfaces cool.

The aircraft should be washed with mild soap and water. Strong, abrasive or alkaline soaps or detergents can scratch painted or plastic surfaces and can corrode metal. Cover areas where the cleaning solution could cause damage.

- **CAUTION:** Do not use a pressure washer; use a bucket of cleaning solution and a sponge.

- Rinse off loose dirt with water;
- Apply the cleaning solution with a soft cloth, a sponge or a brush with soft bristles;
- To remove exhaust residue, allow the cleaning solution to soak in for a while;
- Thoroughly rinse all the surfaces.

A good quality automobile wax, not containing silicones, can be applied to the painted surfaces for protection. Use soft cloths or a chamois leather to avoid scratching the surfaces during cleaning and polishing.

Windscreens and windows

Before cleaning the acrylic windows, rinse all loose dirt off before applying a cloth or chamois leather. Acrylic should never be rubbed dry. It is possible to remove scratches with a special polishing paste intended for acrylic.

- **CAUTION:** Only use a product intended for acrylic, non abrasive, anti-static, solvent free, for cleaning the windows. Only use a non-abrasive cotton cloth or real chamois leather to clean the acrylic windows. Paper towels and newspaper are very abrasive and will leave scratches.

Cleaning the interior surfaces

Vacuum clean the seats, carpets, trim panels and headlining at regular intervals to remove dirt and surface dust. During vacuuming, use a fine nylon brush to help dislodge the dust.

- **CAUTION:** Remove any sharp objects from pockets and clothing to avoid damaging the internal panels and the trim.

Panels and electronic display screens

Simply wipe the panels, control knobs and plastic surfaces with a soft, damp, cloth. Multifunction display screens, primary flight display, and other electronic displays must be cleaned according to the manufacturer's instructions.

Carpet

To clean the carpets, remove dirt with a brush or vacuum cleaner. For stains, use a non-flammable dry cleaning product.

SECTION 9 :

REGISTER OF SUPPLEMENTS

List of installed supplements

N° document	TITRE	Installé	
		oui	non
—	Panel	<input type="checkbox"/>	<input type="checkbox"/>
1001114	Garmin GNS 430	<input type="checkbox"/>	<input type="checkbox"/>
1001168	S-TEC System 20&30 autopilot	<input type="checkbox"/>	<input type="checkbox"/>
1001287	GPS GARMIN 100AVD for VFR use in sight of the surface	<input type="checkbox"/>	<input type="checkbox"/>
1001305	GPS GARMIN 150XL for VFR use in sight of the surface	<input type="checkbox"/>	<input type="checkbox"/>
1001306	BENDIX/KING KMD 150 for VFR use in sight of the surface	<input type="checkbox"/>	<input type="checkbox"/>
1001840	VFR night	<input type="checkbox"/>	<input type="checkbox"/>
1002504	GPS GARMIN 695	<input type="checkbox"/>	<input type="checkbox"/>
1002530	GPS/SBAS GTN625, 635, 650, 725, 750	<input type="checkbox"/>	<input type="checkbox"/>
1002531	G500	<input type="checkbox"/>	<input type="checkbox"/>
1002545	GARMIN GTN 750	<input type="checkbox"/>	<input type="checkbox"/>
1002554	S.A.M	<input type="checkbox"/>	<input type="checkbox"/>
1002559	IFR	<input type="checkbox"/>	<input type="checkbox"/>
1002571	S-TEC System 55X autopilot	<input type="checkbox"/>	<input type="checkbox"/>
1002606	Fire extinguisher	<input type="checkbox"/>	<input type="checkbox"/>
1002618	ASPEN 1000	<input type="checkbox"/>	<input type="checkbox"/>